

Stainless Steel, Wireless Tension Link

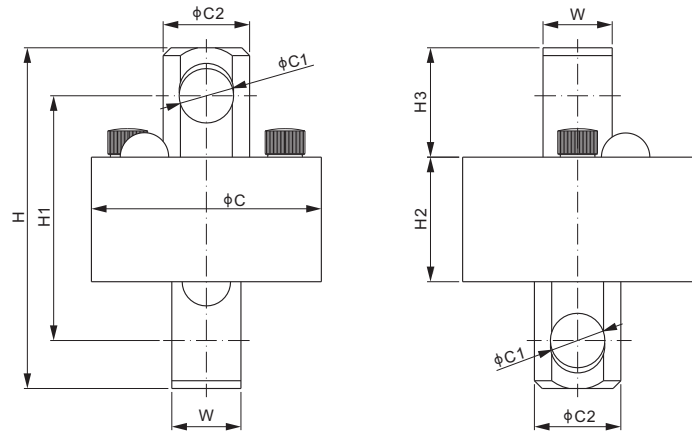

Shackle & indicators to be ordered separately.



DIMENSIONS

RATED CAPACITY	C	C1	C2	H	H1	H2	H3	W	SUGGESTED SHACKLE
t/mm									
1	121	13	25	130.4	104	70	30.7	15.5	TBX-2t
2.5	121	15	25	130.4	104	70	30.7	17	TBX-2.5t
5	121	21	34	157.5	115.5	71.8	43.5	25	TBX-5t or RBXS-5t
10	133	31.5	50	197	141.5	72	63.3	40	TBX-12.5t
Klb/inches (conversion of above dimensions)									
2	4.76	0.51	0.98	5.13	4.10	2.76	1.21	0.61	TBX-2t
5	4.76	0.59	0.98	5.13	4.10	2.76	1.21	0.67	TBX-2.5t
10	4.76	0.83	1.34	6.20	4.55	2.83	1.71	0.98	TBX-5t or RBXS-5t
20	5.24	1.24	1.97	7.76	5.57	2.83	2.49	1.57	TBX-12.5t

SPECIFICATIONS

Division	1:5 000	Rechargeable Battery Type	16340.3 7V x 4 (included)
Max. Safety Load	200%F.S.	Charger	DC 4.2V / 600mA (included)
Ultimate Load	400%F.S.	Operating Temp.	-10°C to 40°C / 14°F to 104°F
Enclosure	Stainless Steel Casting	Operating Humidity	<85% RH under 20°C [68°F]
Transmission Range	Up to 30m	IP Rating	IP68 / 69K
Operation Time	8 hours		

PART NUMBER

Rated Capacity	Frequency	Part No.	Self Weight (kg) (Batteries included)
1t	433 MHz	110ES-1t-WL01	1.7
	915 MHz	110ES-1t-WL02	1.7
2.5t	433 MHz	110ES-2.5t-WL01	1.7
	915 MHz	110ES-2.5t-WL02	1.7
5t	433 MHz	110ES-5t-WL01	2.1
	915 MHz	110ES-5t-WL02	2.1
10t	433 MHz	110ES-10t-WL01	3.5
	915 MHz	110ES-10t-WL02	3.5

TENSION LINKS