

1. Special Features

- Can be connected with 6 load cells
- Each connection has independent adjustable resistance, excitation trim
- Stainless steel casting
- Patented never lost and integrated screw design

2. Dimensions (in mm; 1mm=0.03937 inches)

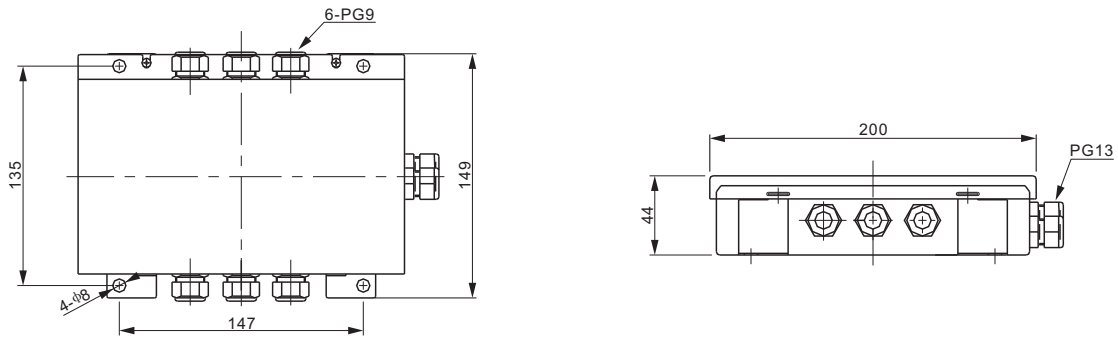

3. Connecting Diagram

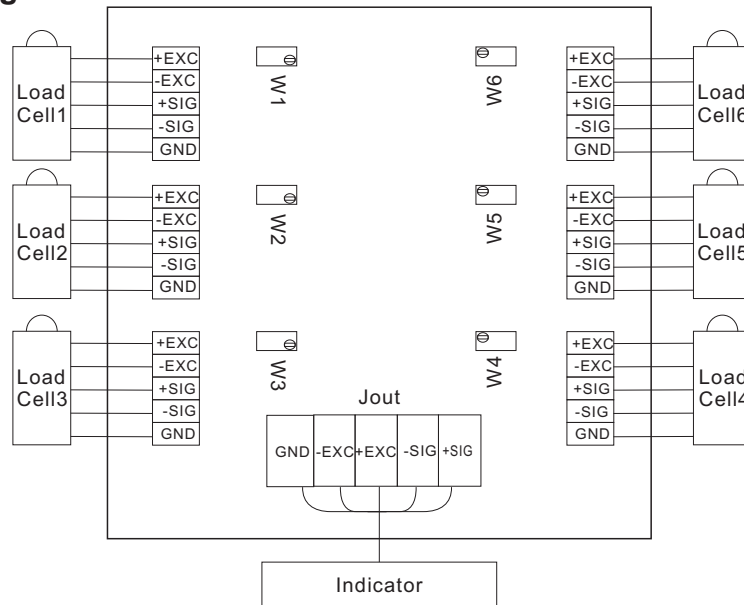

4. Technical Data

Type	J06ES	
Trimming	Excitation trim	
Weight, approx	kg	0.9
Max. Permissible Voltage	V	18
Materials	Stainless steel SS304	
Outline (L*W*H)	mm	200*149*44
Nominal Temperature Range	°C [°F]	-10...+50 [14...122]
Storage Temperature Range	°C [°F]	-20...+60 [-4...140]
Cable Connection for Cable Diameter	Input: PG9: 4-8mm, Output: PG13: 6-12mm	
Protection Class According to IEC529	IP65	

5. Application

6 channel signals generated from the load cells which distributed at the corners of the weighing platform, synthesize into one channel signal and send to the weighing indicator after balance adjustment.

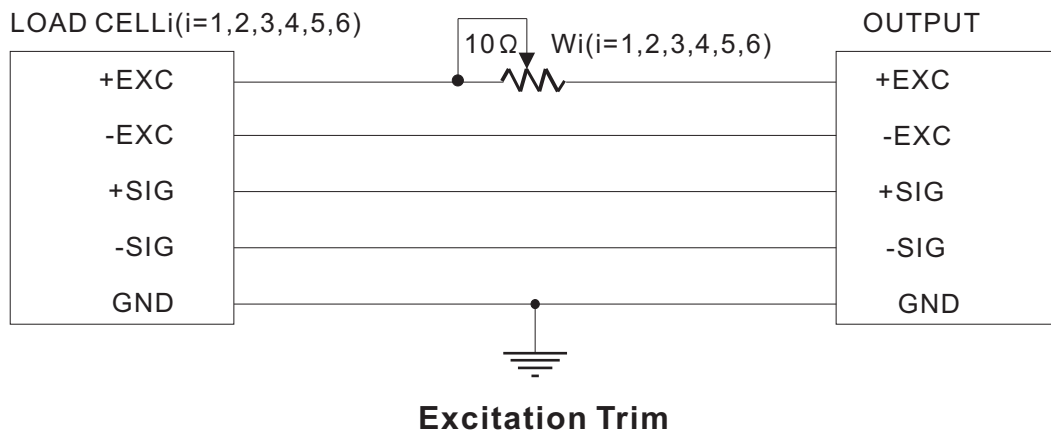

6. Trimming Procedure

Trimming is a process of equalizing the output from multiple individual load cells by adjusting each matched potentiometer.

Tools needed: a) A flat head screwdriver which is good for potentiometer adjustment and a Phillips screwdriver which is good for fasten bolts;
b) A 4.5 digits(at least) multi-meter.

Trimming Steps:

- 1) Connect each load cell cable to the matched terminal of J06ES through PG9 as "Connecting Diagram", connect indicator with a cable through PG13 with J06ES properly as well. Set the indicator to Zero, then place test weights over each load cell (each corner) and on the center point in turn. For a six load cell scale, it's recommended using a weight of 25% of full scale capacity.
- 2) Record the value displayed on the indicator after test weight is placed in turn on each corner and center. Select the lowest corner value comparing with center value, adjust the potentiometer of the corner by clockwise turn to increase the value of this corner, or select the greatest value comparing with center value, then trim the potentiometer of the corner by counterclockwise turn to decrease the value of this corner.
- 3) Replace the same test weight over each cell and center in turn. Adjust the potentiometers to trim each load cell up or down to equal the value of each corner to the center. Check all cells again for repeatability, repeat steps 1 and 2 if necessary until all the value is within the required range.
- 4) Place the box cover on and tighten the cover screws, make sure the gasket is compressed equally in all locations.