

## 805TS & 805BS Series

### General Purpose Digital Weight Indicators

Operations Manual (v1901)

- 805TS-B-17
- 805BS-B-17
- 805BS-TN-B (*Lite Version*)



**TABLE OF CONTENTS**

1.	Introduction and Product Features	3
2.	Safety Recommendations	4
3.	Operation Modes	5
4.	Front Panel Keypad	6
5.	Indicating Lights and Symbols	7
6.	Start Up	8
7.	Operations	8
	7.1 Basic Configurations of Indicator	8
	7.2 Enable Password Function	9
	7.3 Normal Weighing Mode	10
	7.3.1 Gross/Net Mode	10
	7.3.2 Units	11
	7.3.3 Zero Scale	11
	7.3.4 Acquire Tare	11
	7.3.5 Remove Stored Tare Value	11
	7.3.6 Print	11
	7.4 Peak Mode Operations	12
	7.4.1 Units	12
	7.4.2 Peak/Normal Weighing Mode	12
	7.4.3 Remove Peak Mode Value	13
	7.4.4 Zero Scale	13
	7.4.5 Print	13
	7.5 Count Mode Operations	13
	7.5.1 Gross/Net Mode	13
	7.5.2 Units	14
	7.5.3 Zero Scale	14
	7.5.4 Acquire Tare	14
	7.5.5 Remove Stored Tare Value	14
	7.5.6 Input Item Code	14
	7.5.7 Printing in Count Mode	15
	7.5.8 Fast Setup of Count Items Average Weight	15
8.	Wire Installation	16
	8.1 DC power supply	17
	8.2 SW2 Switch	17
	8.3 KOUT: Relay signal outputs	17
	8.4 SW3: Output: RS485/COM	17
	8.5 SW4: Output: USB/RS232	17
	8.6 Load Cell Input	18
	8.7 COMM: Serial Communication port	18
	8.8 Printers	18

9.	Configurations	18
9.1	Front Panel Configurations	19
9.2	Menu Structure and Parameters Descriptions	20
9.2.1	F1(Configuration) Menu	22
9.2.2	F2(Format) Menu	25
9.2.3	F3(Calibration) Menu	28
9.2.4	F4(Serial) Menu	29
9.2.5	F5(Mode) Menu	31
9.2.6	F6(Relay) Menu	32
9.2.7	F7(Ver) Menu	34
9.2.8	F8(PFormat) Menu	35
10.	Calibration	36
11.	Counted Items Average Weight Setup	39
12.	Relay Output Setup	42
13.	Print Format	43
13.1	Print Format Commands	44
13.2	GFMT and NFMT Print Format Input	45
13.3	Default Print Formatting	47
13.4	Printing Consecutive Numbers	47
13.5	Date and Time Settings	48
14.	Serial Communication	49
14.1	Continuous Transmission	50
14.2	Transmission Upon Request	50
14.2.1	Data Transmission Sequence	51
14.2.2	Communication Command	52
15.	Appendices	54
15.1	Error Messages	54
15.2	Software Version and Default Configuration Parameters	54
15.2.1	Find out the indicator's software version	54
15.2.2	Restore to Factory Setup	55
15.3	Technical Specifications	56
15.4	ASCII Codes Table	57
15.5	Indicator Display Characters	58

## 1. Introduction and Product Features

Thank you for choosing Anyload General Purpose Digital Weight Indicators. The 805TS and 805BS series indicators are general purpose indicators that provide high accuracy and reliability with multiple functions. These indicators have an A/D adopted conversion technology of a 24-bit resolution with a rate of conversion of up to 960 cycles per second and drives up to eight 350Ω or sixteen 700Ω load cells through a junction box. With a SS304 stainless steel wash down enclosure, the 805TS and 805BS are ideal for food industry, agricultural industry, and industrial applications. These indicators are NTEP III/IIIL, 10000 and Measurement Canada III, 10000; III HD 20000 approved.

### Key Features:

805TS	805BS Series
Parameter settings and calibration procedures are performed at the front panel	
Auto zero scale can be selected when switching on indicator	
Auto zero tracking	
Unit switch between kg & lb	Unit Selection: kg, lb, g, oz, lb:oz
0.8 in (20mm) in height red LED display and with option for blue LED	143mm x 41mm LCD white background and blue font display, and with option for blue background and white font
Improper operation and fault indication	
Normal Weighing mode, Peak mode and Count mode functions	
2 way relay signal output ( not available in 805BS-TN-B Lite Version )	
Zero Scale, Tare mode, Gross/Net weight selections	
Equipped with RS232C and RS485 connecting port with options for Data Transmitted Continuously and Data Transmitted Upon Request	
Print functions with programmable print format (with build-in clock to show dates and hours	
Can drive up to eight 350Ω or sixteen 700Ω load cells through a junction box	

This manual provides installation, operation and configuration information of the indicator models 805TS and 805BS series. It is recommended to go through the manual in details before installing, operating or configuring the instrument.

## Checking What is in the Box:



805TS or 805BS indicator



Operations Manual



Power Adapter for 805TS & 805BS series

## 2. Safety Recommendations

Important instructions, which involve safety, are highlighted with the appropriate mark:



When it is required to work inside the indicator enclosure for some procedures described, the work can only be performed by qualified technical personnel.

When using the equipment in surroundings with increased safety requirements, the corresponding regulations must be observed:

The indicator may only be used with the power adapter supplied exclusively for use with the device.

Before inserting the power adapter, the user must ensure that the operating voltage stated on the power adapter agrees with the mains voltage.

If not, please contact Anyload Customer Service.

If the power adapter or its cable is damaged, the indicator must immediately be disconnected from the electricity supply (pull out the power adapter).

These operating instructions must be read by each operator of the equipment and must be available at the workplace at all times.

### 3. Operation Modes

#### ❖ Weighing Mode

When the jumper of SW2 is removed or set to DFT, the indicator will switch to weighing mode. Refer to Section 8 in switching the indicator to configurations and weighing mode.

In F5.1 Menu, three different Weighing modes can be selected (refer to F5.1 Configurations Menu):

- (1) **Normal Weighing mode:** Indicator displays gross weight or net weight in this mode. Unit of the displayed weight is highlighted by indicator light and different units can be toggled (refer to Section 7.3).
- (2) **Peak mode:** Indicator displays peak value of load acted upon the weighing instrument (refer to Section 7.4).
- (3) **Count mode:** Indicator displays number of weighed items having the same weight (refer to Section 7.5).

#### ❖ Configurations Mode

When the jumper of SW2 is set to CFG, the indicator will switch to configurations mode and the display will show F1. Refer to Section 8 in switching the indicator to configurations and weighing mode.

Most of the operation data settings including parameter settings and weighing range calibration are to be carried out at Configurations mode.

Remove the back panel of indicator (refer to Fig 8.1 Sockets on mainboard). Switch the jumper of SW2 to CFG setting. Indicator should be in Configurations mode and display will show “F1”. Refer to Section 9 for details.

#### 4. Front Panel Keypad

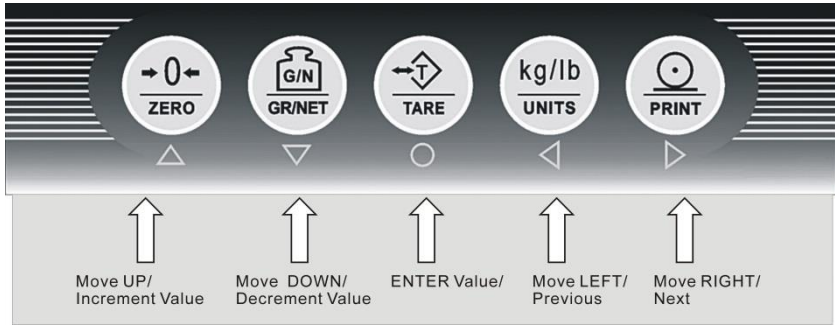

Fig. 4.1 Front Panel Configuration of 805TS

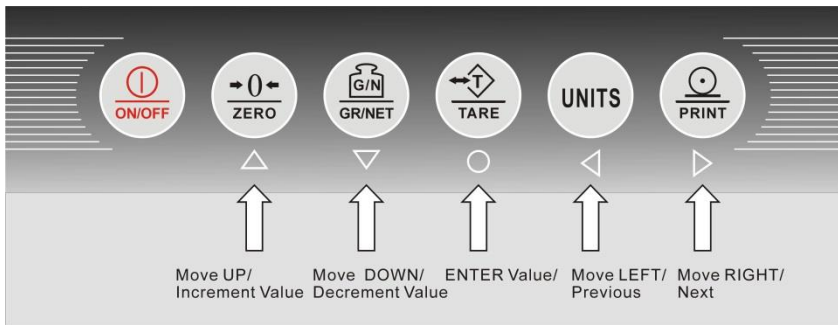







Fig. 4.2 Front Panel Configuration of 805BS series

Fig.4.1 and Fig.4.2 are the indicators' front panel configuration that will indicate the LED/LCD indicator lights/symbols and keypad configurations. Signs or symbols under the keys are for configuration operation use (refer to Section 9 for details).

The signs/symbols can be used for inputting item codes during the Count Mode (refer to section 7.5 for details).

## 5. Indicating Lights and Symbols

Indicating Lights for 805TS	Indicating Symbols for 805BS Series
“ <b>Peak</b> ”— Peak light is on when operating in Peak mode	“  ”—Peak symbol is displaying when operating in Peak mode
“ <b>Count</b> ”— Count light is on when operating in Count mode	“  ”—Count symbol is displaying when operating in Count mode
“ <b>kg</b> ”— kg light is on showing units in kg.	“kg”— is displaying showing units in kg.
“ <b>lb</b> ”— lb light is on showing units in lb.	“lb”— is displaying showing units in lb.
N/A	“g”— is displaying showing units in g
N/A	“oz”— is displaying showing units in oz
N/A	“lb:oz”— is displaying showing units in lb:oz.
“ <b>Gross</b> ”— Gross light is on when display showing gross weight	“  ”— Gross symbol is displaying showing gross weight.
“ <b>Stable</b> ”— Stable light is on when the load is stable or within the preset dynamic load range (refer to F1.4 Menu for dynamic load setting).	“  ”— Stable symbol is displaying when the load is stable or within the preset dynamic load range (refer to F1.4 Menu for dynamic load setting).
“ <b>Zero</b> ”— Zero light is on when load is within zero range (<1/4d).	“  ”— Zero symbol is displaying when load is within zero range (<1/4d).
“ <b>Tare</b> ”— Tare light is on when Tare setting is not zero	“  ”— Tare symbol is displaying when Tare setting is not zero

## 6. Start up

Connect power supply. For the 805TS, the indicator will automatically go through a self-checking process (showing all 0’s to all 9’s, decimal point and indicator lights). For the 805BS series, press the ON/OFF key at the front panel for 2 seconds to turn on the unit. Once on, the indicator will undergo a self-



checking process. There are two possible outcomes depending on parameter settings at F1.8 and F1.9 Menus:

- When indicator is set to Auto Zero (F1.8=0 and F1.9=1), respectively, and the load on the scale is within the zero scale setting in F1.3, the indicator will zero the scale automatically upon returning it on.
- Otherwise, if F1.8=1 & F1.9=0, the indicator will display the current weight of the load in the scale upon returning it on. The manual zeroing of scale can be achieved if the load on the scale is within the zero scale setting in F1.3.

Refer to F1.3 Menu along with the F1.8 & F1.9 Menu for further information.

## **7. Operations**

### **7.1 Basic Configurations of Indicator**

*It is recommended to calibrate the indicator before using it in your scale system. Calibration requires a test weights or any known weights with at least 30% of the maximum capacity of your scale system. The 805 indicator will have higher accuracy if the value of test weights (span weights) is closer or equal to its maximum capacity ( e.g. 100kg max capacity scale shall require at least 30 kg test weight or known weights to calibrate ). Refer to Section 10 of this manual for the details of calibrating the indicator.*

1. Open the back panel of the indicator. Install the wires from your load cell to the load cell terminal at the mainboard. Refer to Section 8 of this manual for the wiring installation.
2. Identify if the load cell is a 6 or a 4-wire. By default it is set to a 4-wire configuration. If the load cell has 6 wires, move the two jumpers of SW1 to 6W setting. Refer to Section 8.
3. Once load cell wires are hooked up, move the jumper of SW2 to CFG setting to enter Configurations Mode. The indicator will display F1.
4. Set the value of graduations. The graduations shall be equal to maximum capacity of the scale divided by the scale division. For example, you will set a scale of 100kg max capacity and a division of 0.1kg, the graduations should be  $100\text{kg}/0.1\text{kg}=1000$ . For 0.01 division, the graduations should be 10000 and so on.
5. Enter the value of graduations in F1.1 submenu. Refer to Section 9.2 for menu operation flow diagram. Once F1 is displayed, press Arrow down key to enter F1.1. Press Arrow down key again, '00000' will display. Press Arrow right or left key to move

- to next digit and Arrow down or up key to change values. To enter the value of 1000 it should be '001000' then press the Enter/Tare key to save.
6. Set the primary unit ( lb or kg ) and division of your scale. To set the primary unit, go to F2.1 submenu. Refer to Table 9.2.2 for the parameter value of units for 805TS & 805BS. Go to F2.2 to set the decimal point. Go to F2.3 to set the increment of your scale division. Note, your settings here will affect the value of graduations in F1.1. For example, if you have 100kg max scale and set to have 2 decimal points and 5 units increment (0.05 division) then the value in F1.1 should be 2000.
  7. Once the graduations value and scale division are set, you are now ready to calibrate the indicator. Refer to Section 10 for the details of calibration procedures.
  8. Once calibration is successfully done, move back the jumper of SW2 to DFT setting to return the indicator to Weighing Mode.

## **7.2 Enable Password Function (Entering or exiting Configurations Mode)**

*The password function is a feature in which the user will enter the password to switch the indicator from Weighing Mode to Configurations Mode or vice versa without opening the back panel of the indicator. **This feature is only applicable if legal-for-trade is not required like NTEP, OIML or Measurement Canada.***

- (1) To enable the password function, the parameter value in F6.1 should be 3 (F6.1=3) and F6.4 should not equal to 00000.
- (2) Open the back panel and set the indicator to Configurations mode by switching the jumper of SW2 to CFG setting.
- (3) Go to F6.1 menu and set the value to 3 (F6.1=3) then save by pressing the tare key. Skip to F6.4 and you will set your desired password. The display will show P00000. The password should not equal to 00000. For example, if you want your password to be "11111", edit the value in F6.4 to P11111 then save by pressing the tare key. Do not switch and keep the jumper of SW2 at always CFG setting. To check if the function is activated, set the indicator to display at main menu like F1, F2 or F8. Hold and press the Tare key and should ask your password (will display P00000). This indicates that the password function is activated. Re-install the back panel and remember keeps the jumper of SW2 at CFG setting.

- (4) To enter the Configurations mode, hold and press the TARE key until password dialog pops up. The display will show P00000. Enter your password and press tare key. The display should display F1 meaning you are in the Config Mode.
- (5) To exit the Configurations mode, set the indicator to display at main menu like F1, F2 or F8 then hold and press the TARE key until password dialog pops up. The display will show P00000. Enter your password and press tare key. The indicator should return to Weighing mode.
- (6) To deactivate the password function, go to Configurations mode and set the value in F6.4 to "00000". Press tare key to accept the changes.

*If ever the user forgotten the password, input "26956" as password to reset the password to 00000 and deactivate the password function. To re-enable the function, switch to Configurations Mode and follow the instructions above from 1 to 6.*

The indicator goes to Weighing mode when the jumper of SW2 is set to DFT. Under the Normal Weighing mode, the Peak mode and Count mode can be set at F5.1 Configuration Menu (refer to F5.1 Menu).

### 7.3 Normal Weighing Mode

When the indicator is set to Normal Weighing Mode, the parameter value in F5.1 should be F5.1=0 (refer to F5.1 Menu).

For 805TS (F5.1=0), the "Peak" light and "Count" light are off. Indicator is in Normal Weighing mode.

For the 805BS series(F5.1=0), both "Peak" and "Count" symbols won't appear in the display. Indicator is in Normal Weighing mode.

Basic operations in Normal Weighing mode:

#### 7.3.1 Gross/Net Mode

Pressing **【GR/NET】** will change to Net weight from Gross weight mode or vice versa. When tare weight is stored (indicator has stored tare weight value other than 0).

Net weight shown on the display is equal to Gross weight minus the Tare weight. For the 805TS, the "Gross" light is on when indicating gross weight and the "Net" light is on when indicating net weight while the 805BS series the "Gross"

symbol will display when indicating gross weight and “Net” symbol will display when indicating net weight.

### **7.3.2 Units**

When parameter in F2.7 is set to 1 (F2.7=1), **【UNITS】** key is disabled and will not switch to the secondary unit. When parameter in F6.1 menu is set to OIML (F6.1=1), only metric units like kg and g are recognized. Setting the F2.7=0, switching from primary to secondary unit or vice-versa is allowed. Press the **【UNITS】** key in changing units. For 805TS series, the corresponding lights on the far right side of the screen indicate which unit type is currently set while for 805BS series, the unit symbol appears in the display like kg, lb or oz.

### **7.3.3 Zero Scale**

When in Gross mode (“Gross” light is on for 805TS series and “Gross” symbol is displaying for the 805BS series). Remove the load from scale and wait until the “Stable” indication is displaying. Press **【ZERO】** and the “Zero” light should turn on (for 805TS series) while “Zero” symbol should display (for 805BS series). This indicates that the Zero Scale setting is complete

### **7.3.4 Acquire Tare**

When no Tare is stored (“Tare” light is off), place the container on the scale and wait until the “Stable” indication is displaying. Pressing **【TARE】** will store the Tare weight. If “Net” light is on (805TS series) or the “Net” symbol is displaying (805BS series), the display is showing the Net weight (refer to F6.1 Menu).

### **7.3.5 Remove Stored Tare Value**

When a tare weight is stored (“Tare” light is on or “Tare” symbol is displaying), press **【TARE】** to remove the stored tare value. The display will show the Gross weight and the “Gross” light (805TS series) will turn on or the “Gross” symbol will display (805BS series)(refer to F6.1 Menu).

### **7.3.6 Print**

Ensure that the “Stable” indication is on then press **【PRINT】**. Data from indicator is then transmitted to a serial printer for printing. After each printing, the Consecutive Number is increased by 1. The print format is set according to F8 Menu (refer to Section 13 for Print Format).

## 7.4 Peak Mode Operations

Peak mode is disabled in NTEP, Measurement Canada and OIML mode. Set the parameter in F6.1 to 3 (F6.1=3 NONE) then set the parameter in F5.1 to 1 (F5.1=1) to activate the Peak mode. If F5.1=1, the “Peak” light will turn on (805TS series) or the “Peak” symbol will display (805BS series) then the indicator is in Peak mode (refer to F5.1 Menu setting).

When in Peak mode, the display will show gross weight. Press the **【GR/NET】** key to switch between Peak and Normal Weighing modes. Pressing the **【TARE】** key will remove the current peak value and reset to zero.

**Basic operations in Peak mode include:**

### 7.4.1 Units

When Peak mode operation is deactivated (“Set” light is off for 805TS and “Peak” symbol is not displaying for 805BS), pressing the **【UNITS】** key will switch to the available units like kg, lb, or oz.

When Peak mode operation is activated (“Set” light is on for 805TS and “Peak” symbol is displaying for 805BS)), the **【UNITS】** key is disabled and will not switch to available units.

### 7.4.2 Peak/Normal Weighing Mode

When “Set” light is on (805TS) or “Peak” symbol is displaying (805BS), the Peak mode is activated. The display will show the maximum value of load which has been applied to the load cell. When the load is removed, the display will still show the peak value of the load.

Pressing **【GR/NET】** will change indicator from Peak mode to Normal Weighing mode, or vice versa.

When “Set” light is off (805TS) or “Peak” symbol is not displaying (805BS), Peak mode is deactivated. The value showing in the display changes according to the load applied to the load cell.

### **7.4.3 Remove Peak Mode Value**

During the Peak mode, remove the load and press **【TARE】** key. The current Peak mode value will be reset and the indicator will start for another Peak mode operation.

### **7.4.4 Zero Scale**

During the Peak mode, pressing the **【GR/NET】** key will switch the indicator to Normal Weighing mode or vice versa. Remove the load and when the “Stable” indication is displaying, press **【ZERO】**. The display will show the zero value.

### **7.4.5 Print**

When Peak mode is on (“Set” light is on or Peak symbol is displaying), pressing the **【PRINT】** key will print the Peak value. When the Peak mode is off (“Set” light is off or Peak symbol is not displaying), pressing the **【PRINT】** key will print the current load value. After each printing, the Consecutive Number is increased by 1. The Print format can be set at F8 Menu. To print the Peak value, ensure that peak command is added properly in the Print format settings (refer to Section 13 for Print Format).

## **7.5 Count Mode Operations**

Count mode is disabled in NTEP, Measurement Canada and OIML mode. Set the parameter in F6.1 to 3 (F6.1=3 NONE) then set the parameter in F5.1 to 2 (F5.1=2) to activate the Count mode. If F5.1=2 the indicator will turn to Count Mode- “Count” light is on for 805TS series or “Count” symbol is displaying for 805BS series. The indicator will now perform Count operations (refer to F5.1 Menu).

### **Basic operations in Count mode:**

#### **7.5.1 Gross/Net Mode**

Pressing the **【GR/NET】** key will switch between Gross and Net weight mode. When in Tare mode, Net weight is equal to Gross weight minus Tare weight. The “Gross” light is on (805TS series) or the “Gross” symbol is displaying (805BS series) when in Gross mode and the “Net” light is on (805TS series) or the “Net” symbol is displaying (805BS series) when in Net mode.

### 7.5.2 Units

Pressing the **【UNITS】** key will switch between the weight of load and the equivalent quantity of counted items. When showing the weight of load, refer to F2.1 Menu to choose the units. When showing the quantity for the counted items, the display will show “nxxxxx”. xxxxx is the quantity of counted items.

### 7.5.3 Zero Scale

When in Gross mode (for 805TS series, the “Gross” light is on; for 805BS series the “Gross” symbol is displaying), remove the load from scale. After the “Stable” light is on (805TS series), or the “Stable” symbol is displaying (805BS series), pressing the **【ZERO】** key will let the “Zero” light or symbol to turn on. The Zero Scale setting is completed.

### 7.5.4 Acquire Tare





When no Tare is stored (“Tare” light or symbol is off), place the container onto the scale and wait until the “Stable” light is on (805TS series), or “Stable” symbol is displaying (805BS series). Press the **【TARE】** key and Tare value (weight of container) will be stored. The display will show the Net weight and the “Net” light (805TS series) will turn on, or the “Net” symbol will display (805BS series) (refer to F6.1 Menu).

**Note: Only the displaying tare value that is less than 6 digits can be successfully stored, otherwise, the tare option will not activate.**

### 7.5.5 Remove Stored Tare Value

When a tare value is stored (for the 805TS series, the “Tare” light is on; for the 805BS series, the “Tare” symbol is displaying), press **【TARE】** to remove the stored value. The display will show the Gross weight and the “Gross” light (805TS series) will turn on, or the “Gross” symbol (805BS series) will display (refer F6.1 Menu).

### 7.5.6 Input Item Code

When in Count Mode, press **【PRINT】** to go to Input Item Code status. Display will show “P= xx”, where xx is the code number of the current count item and x flashes. Now the functions of the keypad become , , , , .

▶, ◀ are for moving forward and backward while ▲, ▼ are for increasing and decreasing the digit value. Upon completing Input Item Code, press the ○ key if the stored Item Code is not 00. Item Code of the current count items is then stored and the keypad returns to normal operating function as shown in Fig. 4.1 (805TS series) and Fig.4.2 (805BS series).

If the stored Item Code =00, the indicator goes to the Fast Setup of the Average Weight of the Counted Items (refer to Section 7.5.8).

### 7.5.7 Printing in Count Mode



If the indicator is showing the weight of the load, the **【PRINT】** key is reserved for entering the count code settings. If the display is showing the quantity of counted items then **【PRINT】** key will print either the GFMT or NFMT text depending if the indicator is in Gross or Net mode.

### 7.5.8 Fast Setup of Counted Items Average Weight

To obtain the average weight of the counted items without going into the Configuration mode, follow these procedures below:

- (1) Set the indicator into weighing mode and remove all the loads to set the scale into zero or no load status. We will be doing the zero calibration.
- (2) Once the scale is stable, press the **【PRINT】** key and the display will show “P = 00”. Keep the value of “P = 00” then press ○ key to start zero calibration. The display will show CAL indicating the calibration is in progress.
- (3) After the zero calibration, we will proceed to the Counted Items Average Weight Setup. The display will show “n=0010”. Use ◀, ▶ to select the suitable sample quantity for the total load to be loaded in the scale. The average weight of each sample will be calculated as Total weight value divided by the total sample quantity. Select a larger quantity for lighter counted items.
- (4) Put the load equivalent to the total sample quantity entered from the previous step. Press ○ key and the display will show “CAL” indicating calibration is in progress. When completed, there are maybe two possible outcomes:



- Display will show “- - E5 - -” when the average weight of the counted items is too small. Refer to these two options:
  - Combine a few counted items to become one counted item. Place the same quantity of counted items to the scale as per the sample quantity set in (3) above. Press  to calculate the average weight.
  - Press  to cancel Counted Items Average Weight Setup and return to Weighing mode.
- Display will show the counted items total weight and will return to Weighing mode.

*Note: In this procedure, the settings for counted items average weight is temporary and will be erased once the indicator is switched to other mode or the indicator is restarted. If you want to save a counted items average weight settings refer to section Section 11.*

## 8. Wire Installation.

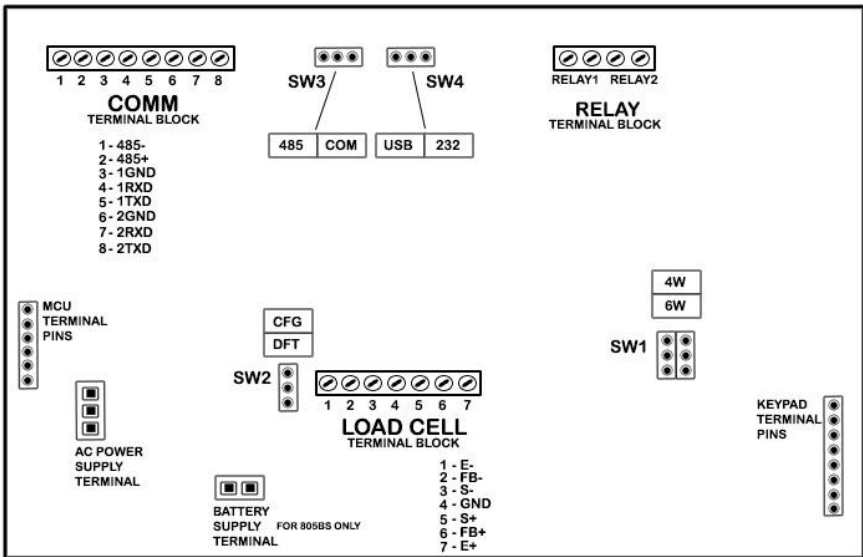

Fig. 8.1 Sockets on mainboard for 805TS & 805BS series

*Note: When using a 4-wire load cell, move the two jumpers of SW1 to 4W. When using a 6-wire load cell, move the two jumpers of SW1 to 6W.*

### 8.1 Power supply

805TS-B-17	Input : 120VAC, 60Hz, 110mA Output : 9VDC 600mA
805BS-B-17 & 805BS-TN-B	Input : 120VAC, 60Hz, 110mA Output : 12VDC 400mA

### 8.2 SW2 Jumper Switch

The SW2 jumper is used to switch between configurations and normal weighing mode. When it is set to CFG, the indicator will switch to configurations mode while in DFT will switch to normal weighing mode.

### 8.3 KOUT: Relay signal outputs

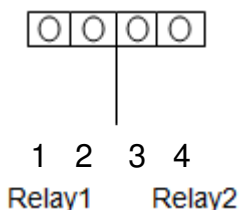

Relay Output of 805TS-B-17 & 805BS-B-17

### 8.4 SW3 Jumper Switch: Output: RS485/COM

The SW3 jumper is to switch between RS485 output and COM mode. When the jumper is moved to 485 setting, the serial output will be in RS485 standard, otherwise, the COM mode is activated.

*Note: Only 805TS-B-17 & 805BS-B-17 have this option ( not equipped in 805BS-TN-B ).*

### 8.5 SW4 Jumper Switch: Output: USB/RS232

The SW4 jumper is to switch between USB and RS232 mode. When the jumper is moved to 232 setting, the serial output will be in RS232 standard, otherwise, the USB mode is activated.

## 8.6 Load Cell Input

805TS-B-17, 805BS-B-17 & 805BS-TN-B
1 (E-) — Excitation-
2 (FB-) — Sense-
3 (S-) — Signal-
4 (GND) — Signal ground
5 (S+) — Signal+
6 (FB+) — Sense+
7 (E+) — Excitation

## 8.7 COMM: Serial Communication port

805TS-B-17, 805BS-B-17 & 805BS-TN-B
1 (485-) — RS485-
2 (485+) — RS485+
3 (1GND) — Signal ground (connect to computer)
4 (1RXD) — RS232C Receipt port 1
5 (1TXD) — RS232C Output port 1
6 (2GND) — Signal ground (connect to computer)
7 (2RXD) — RS232C Receipt port 2 (Printer)
8 (2TXD) — RS232C Output port 2 (Printer)
Note: RS485 is not available in 805BS-TN-B

## 8.8 Printers & Serial Data Output

When hooking up a printer to the indicator, use the COMM terminal block port numbers (6) 2GND, (7) 2RXD, and (8) 2TXD shown in Fig.8.1 while terminal block port numbers (3) 1GND, (4) 1RXD, and (5) 1TXD are for serial data out. To ensure the indicator is able to print on command set the serial mode in F4.3 equal to 1 (comm).

## 9. Configurations

Configure the indicator in the following steps:

- Remove the back panel of indicator.
- Set the jumper in SW2 to CFG. If the input is a 6-wire load cell, set the jumpers of SW1 to 6W, otherwise, set the jumpers to 4W
- Indicator should switch to Configuration mode and will display “F1” - the

first Menu item of Level 1 Submenu.

- When configuration is completed, move back the jumper of SW2 to DFT setting to exit from Configuration mode. ( Refer to Section 7.1 for Basic Configurations )

### 9.1 Front Panel Configurations

When configuring the indicator the keypad functions are shown in Fig. 9.1.1 and Fig 9.1.2

Table 9.1 Basic Functions of Level 1 menu:

Menu		Menu Function
F1	Config	Configure graduations, zero tracking, zero range, motion band, overload, sample rate, digital filtering and zero scale. See Section 9.2.1.
F2	Format	Set decimal point location, display divisions and display unit. See Section 9.2.2.
F3	Calibration	Calibrate indicator. See Section 9.2.3 and Section 10.
F4	Serial	Configure serial communication ports. See Section 9.2.4 and Section 14.
F5	Mode	Set weighing mode and unit weight of counted items. See Section 7, Section 9.2.5 and Section 11.
F6	Relay	Set Relay operation modes. See Section 9.2.6 and Section 12.
F7	Ver	Indicate software version and regenerate default configuration parameters. See Section 9.2.7 and Appendix 15.2.
F8	PFormat	Set print format. See Section 9.2.8 and Section 13.

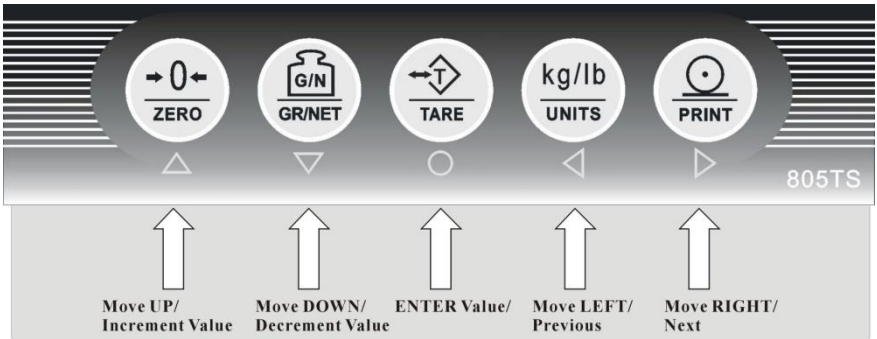

Fig. 9.1.1 Keypad functions in Configuration Mode for 805BS series

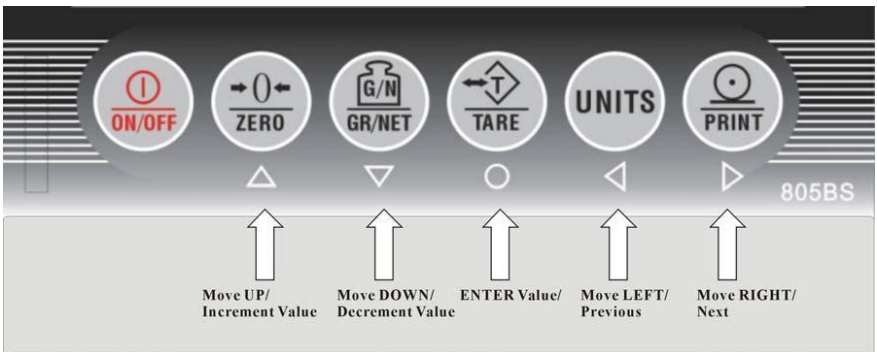
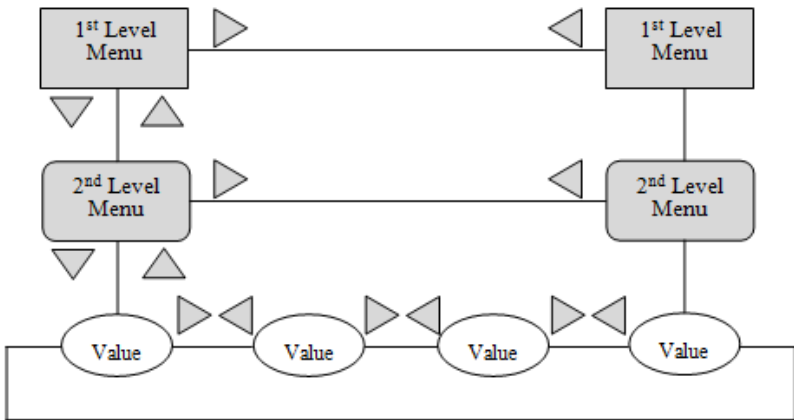

Fig. 9.1.2 Keypad functions in Configuration Mode for 805TS series

## 9.2 Menu Structure and Parameters Description

Menu structure is shown in diagram below. In the actual Menu structure, the selected Menu item is displayed horizontally. In most Menus, setting parameters and parameter value are shown in tables. “number” is editable value.



Menu Configuration Flow Diagram

There are 4 directional keys ▶, ◀, ▲, ▼ to be used for configuration operation. ▶, ◀ are for horizontal movement in the same level menu and parameters. ▲, ▼ are for moving up and down through different level menus. ○ is for confirming the choice of parameter from the menu.

Use ▶, ◀ to choose a parameter in a menu and use ▼ to move to the next menu level or parameter. When moving into a parameter of a menu, display will show the previous chosen. When the parameter of a menu is a fixed value, use ▶, ◀ to move horizontally and use ○ to store the selected parameter and will go to the next menu level. When a parameter value of a menu is editable as shown in Fig 9.1.4, directional keys are used to edit the digit selected, and to increase or decrease the value of the selected digit.



Editable Parameter

### 9.2.1 F1 Configuration Menu

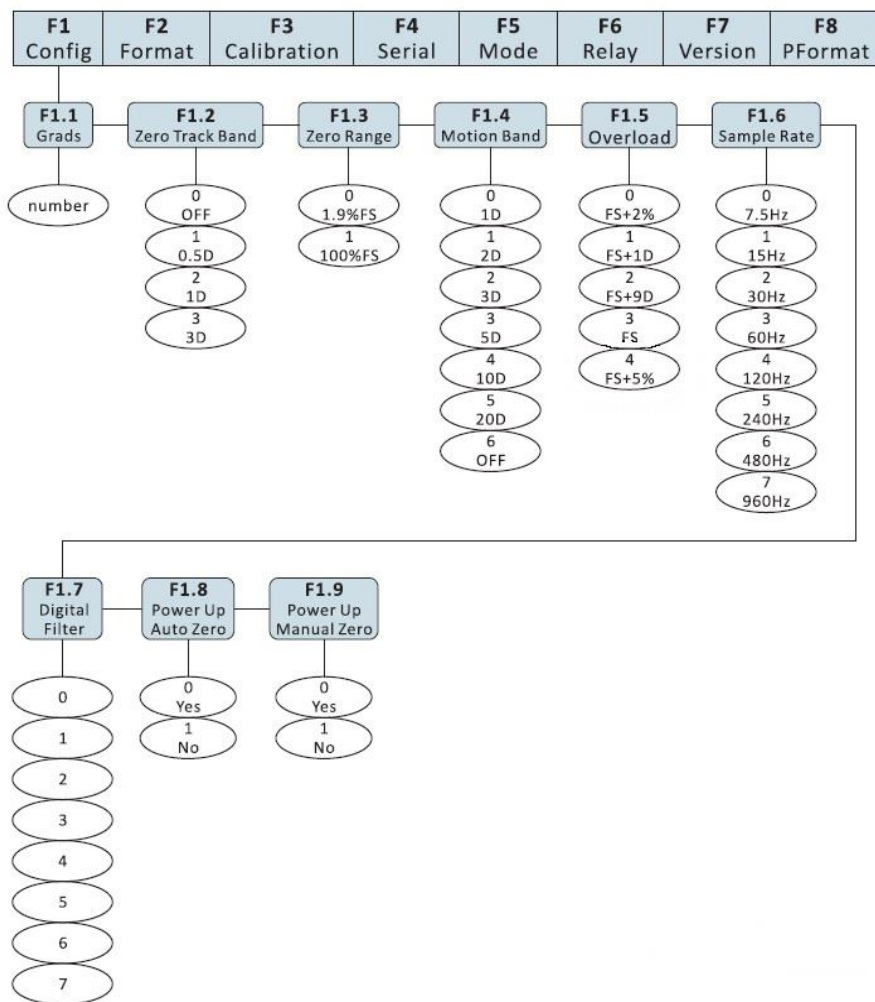

Fig. 9.2.1.1 F1 (Configuration) Menu Structure

**Table 9.2.1 F1 (Configuration) Menu Parameters**

		F1 (Configuration) Menu
Parameter	Choices	Description
Level 2 Submenu		
F1.1 (Grads)	<i>number</i>	<i>Graduations.</i> Specifies the number of full scale graduations. Graduation=Capacity/Display Division. Display divisions for primary and secondary units are specified in the F2 (Format) Menu.
F1.2 (Zero Track Band)	0 (OFF)	<i>Zero track band.</i> Automatically zeros the scale when within the range specified, as long as the input is within the configured zero range. Selections are ± display divisions.
	1 (0.5D) <input checked="" type="checkbox"/>	
	2 (1D)	
	3 (3D)	
F1.3 (Zero Range)	0 (1.9%FS) <input checked="" type="checkbox"/>	<i>Zero range.</i> Selects the range within which the scale can be zeroed. The 1.9% selection is ±1.9% around the calibrated zero point, for a total range of 3.8% FS. FS=Grads * D
	1 (100%FS)	
F1.4 (Motion Band)	0 (1D) <input checked="" type="checkbox"/>	<i>Motion band.</i> Sets the level in display divisions at which scale motion is detected. If motion is not detected for 1 second or more, the “Stable” light is on. Some operations, including Zero, Tare and Print, require the scale to be at standstill. When F1.4 is selected OFF, F1.2 should also be set to OFF.
	1 (2D)	
	2 (3D)	
	3 (5D)	
	4 (10D)	
	5 (20D)	
6 (OFF)		



F1.5 (Overload)	0 (FS+2%)	<i>Overload.</i> Determines the point at which the display shows "OF" indicating the scale is overloaded.
	1 (FS+1D)	
	2 (FS+9D) <b>√</b>	
	3 (FS)	
	4 (FS + 5%)	
F1.6 (Sample Rate)	0 (7.5Hz)	<i>Sample rate.</i> Selects the measurement rate in samples per second of the analogue-to-digital converter. Lower sample rate values provide greater signal noise immunity.
	1 (15Hz) <b>√</b>	
	2 (30Hz)	
	3 (60Hz)	
	4 (120Hz)	
	5 (240Hz)	
	6 (480Hz)	
	7 (960Hz)	
F1.7 (Digital Filter)	0	<i>Digital Filter.</i> Selects the digital filtering rate. The higher the value, the lower is the effects of motion impact the indicator. This results in having a more accurate display. However, it slows down the settling rate of the indicator.
	1	
	2	
	3	
	4 <b>√</b>	
	5	
	6	
	7	
F1.8 (Power Up Auto Zero for 805TS-B-17, 805BS-B-17 & 805BS-TN-B)	0 (Yes) <b>√</b>	<i>Power Up Auto Zero.</i> Specifies to automatically zero the scale when switching on the scale. When selected 0 (Yes), indicator zeros the scale after finishing self-checking.
	1 (No)	
F1.9 (Power Up Manual Zero for 805TS-B-17, 805BS-B-17 & 805BS-TN-B)	0 (Yes)	<i>Power Up Manual Zero.</i> Specifies to restore manually zero the scale when switching it on. When 0 (Yes) is selected, press zero button in the indicator to zero the scale and saves current zero for next powering up.
	1 (No) <b>√</b>	

*Note: Parameters that are in check are the default parameter values.*

9.2.2 F2 ( Format ) Menu

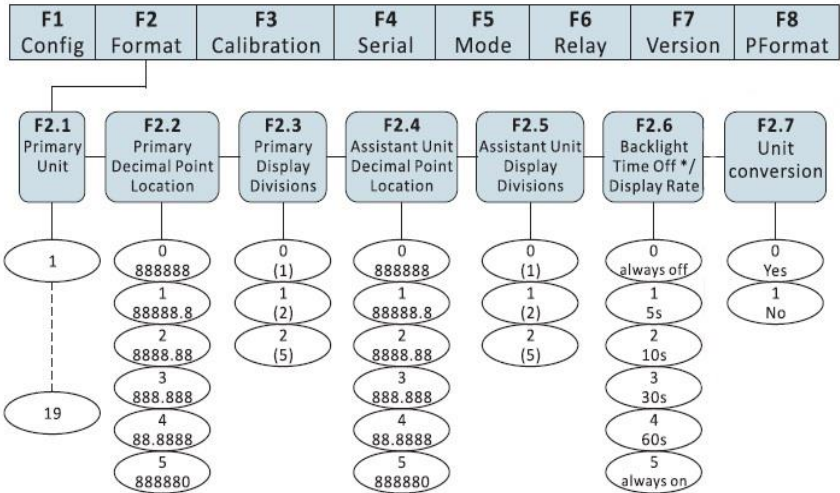

Fig. 9.2.2.1 F2 (Format) Menu

Table 9.2.2 F2(Format) Menu

F2 ( Format ) Menu			
Parameter	Choices		Description
Level 2 Submenu			
	<b>805TS series</b>	<b>805BS series</b>	
F2.1 ( Primary Unit )	0 ( <i>lb</i> )	0 <b>v</b> (P=kg, A=lb)	Specifies the unit used of the Primary unit.  Note : <b>P</b> stands as Primary Unit while <b>A</b> as Assistant Unit
	1 ( <i>kg</i> ) <b>v</b>	1 (P=kg, A=g)	
	N/A	2 (P=kg, A=oz)	
		3 (P=kg, A=lb:oz)	
		4 (P=lb, A=kg)	
		5 (P=lb, A=g)	

	<b>N/A</b>	6 (P=lb, A=oz)			
		7 (P=lb, A=lb:oz)			
		8 (P=g, A=kg)			
		9 (P=g, A=lb)			
		10 (P=g, A=oz)			
		11 (P=g, A=lb:oz)			
		12 (P=oz, A=kg)			
		13 (P=oz, A=lb)			
		14 (P=oz, A=g)			
		15 (P=oz, A=lb:oz)			
		16 (P=lb:oz, A=kg)			
		17 (P=lb:oz, A=lb)			
		18 (P= lb:oz, A=g)			
		19 (P=lb:oz, A=oz)			
		F2.2 (Primary Unit Decimal Point)		0 ( 888888 )	Specifies the decimal position of the Primary unit. Note: If F2.2=5, to edit test weight value in F3.2 the ones place is disabled. You can only
				1 ( 88888.8 ) √	
				2 ( 8888.88 )	
				3 ( 888.888 )	
				4 ( 88.8888 )	

Location)	5 (888880)		change the digit values starting from tens place. For example, if you want to edit the tens place, the cursor must be flashing on the tens place. When a decimal point is changed, you must change the value in F1.1 and then recalibrate (see section 9.2.3).
F2.3 (Primary Unit Display Divisions)	0 (1) ✓		Specifies the display division of the Primary unit.
	1 (2)		
	2 (5)		
F2.4 (Assistant Unit Decimal Point location)	0 (888888) ✓		Specifies the decimal position of the Assistant unit. When F6.1 is set to 0, 1 or 2, the decimal position of the Assistant unit is defined by the decimal position of the Primary unit. When F6.1 is set to 3, the decimal position and display division of the Assistant unit will be defined in F2.4 and F2.5, respectively.
	1 (88888.8)		
	2 (8888.88)		
	3 (888.888)		
	4 (88.8888)		
	5 (888880)		
F2.5 (Assistant Unit Display Divisions)	0 (1) ✓		Specifies the displayed divisions of the Assistant unit.
	1 (2)		
	2 (5)		
F2.6 (Backlight Time Off for 805BS models) <i>Not available in 805BS-TN-B)</i>	<b>805TS &amp; 805BS-TN-B</b>	<b>805BS-B-17 &amp; 805BS-B-H</b>	-Sets the time to off/dim the backlight display for 805BS-B-17 except for 805BS-TN-B  -The update rate for both 805TS and 805BS is 20ms or 50Hz.
	N/A	0 (always off)	
		1 (5s)	
		2 (10s) ✓	
		3 (30s)	
		4 (60s)	
	5 (always on)		

F2.7 ( Toggling Units )	0 ( enable ) v	When F2.7 is set to 0, toggling units is enabled and either primary or secondary unit can be selected by pressing the Units key, otherwise, if F2.7 is set to 1, toggling units is disabled and only the primary unit is activating.
	1 ( disable )	

*Note:*

1. When setting F6.1=0 (NTEP) or F6.1=1 (OIML) or F6.1=2 (Canada), the Assistant Unit Decimal Point Location and its Display Division will change accordingly based on the Primary Unit Decimal Point Location and its Display Division (refer to F6.1 Menu).
2. Parameters that are in check are the default parameter values.

### 9.2.3 F3 ( Calibration ) Menu

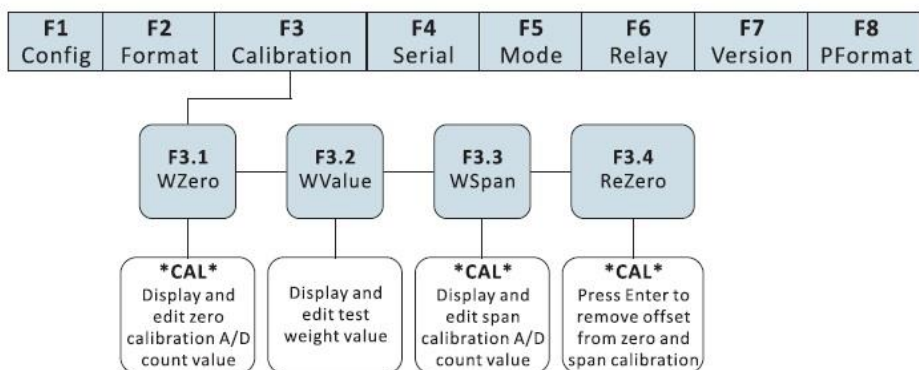

Fig. 9.2.3.1 F3 (Calibration) Menu

**Table 9.2.3 F3(Calibration) Menu**

F3 ( Format ) Menu		
Parameter	Choices	Description
Level 2 Submenu		
F3.1 ( WZero )	—	Display and edit the zero calibration A/D count value. Do not adjust this value after F3.3 (WValue) has been set. Refer to Section 10.

F3.2 (WValue)	—	Display and edit the test weight value, the value entered must above 100. Refer to Section 10.
F3.3 (WSpan)	—	Display and edit the span calibration A/D count value. If re-zero isn't needed, press $\triangle$ to exit, leap over F3.4. Refer to Section 10.
F3.4 (ReZero)	—	Press $\bigcirc$ to remove an offset value from the zero and span calibration. Use this parameter only after F3.1 (WZero) and F3.3 (WSpan) have been set. Refer to Section 10.

### 9.2.4 F4 (Serial Interface) Menu

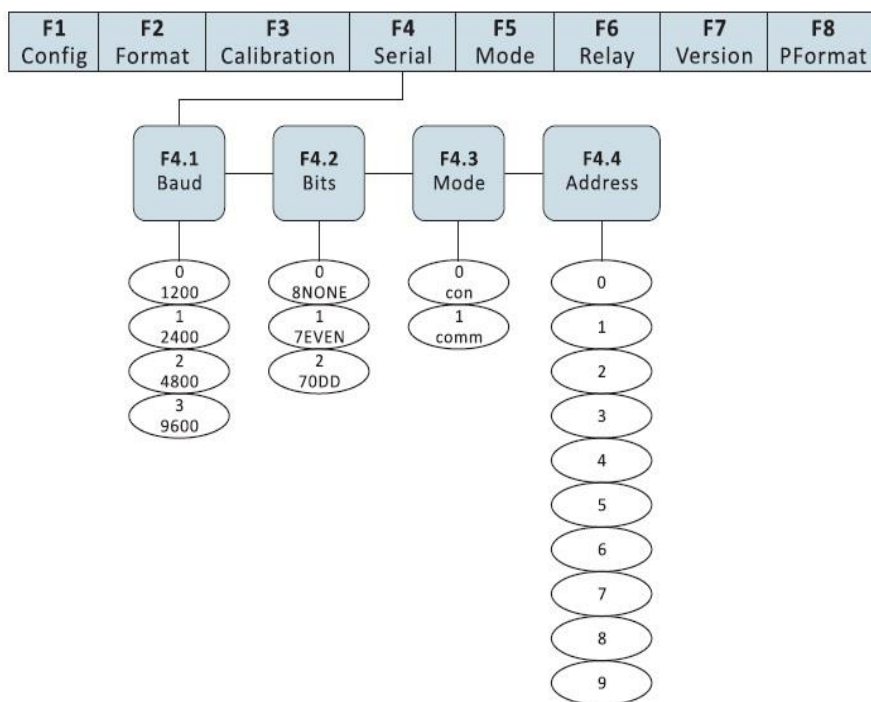

Fig. 9.2.4.1 F4(Serial) Menu

**Table 9.2.4 F4 (Serial) Menu**

F4 (Format) Menu		
Parameter	Choices	Description
Level 2 Submenu		
F4.1 (Baud)	0 (1200)	Specifies settings for baud rate.
	1 (2400)	
	2 (4800)	
	3 (9600) ✓	
F4.2 (Bits)	0 (NONE) ✓	Specifies settings for the number of data bits.
	1 (7EVEN)	
	2 (7ODD)	
F4.3 (Mode)	0 (con) ✓	Selects the mode of data transmission. 0(con) is for continuous transmission and 1(comm) is for transmission upon receiving commands. It must be set to 1 to use print function. Refer to Section 14.
	1 (comm)	
F4.4 (Address)	0 ✓	Select address of serial port.
	1	Note, the serial address must be considered in creating commands to send data to the indicator. Refer to Section 14.2
	2	
	3	
	4	
	5	
	6	
	7	
	8	
9		

9.2.5 F5 ( Mode ) Menu

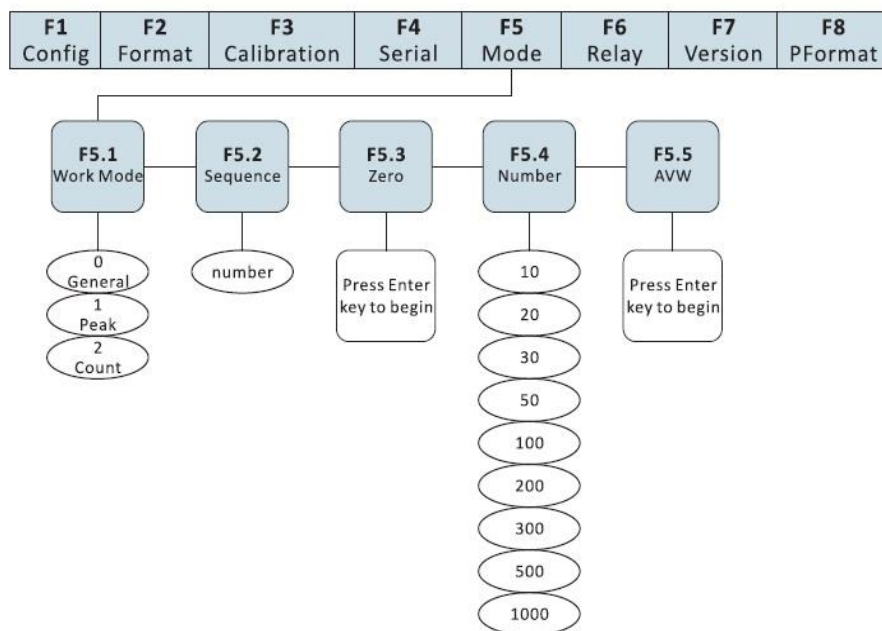

Fig. 9.2.5.1 F5(Mode) Menu

Table 9.2.5 F5(Mode) Menu

F5 ( Mode ) Menu		
Parameter	Choices	Description
Level 2 Submenu		
F5.1 ( Work Mode )	0 ( General ) ✓	Selects one of the three operation modes. Refer to Section 7 for the descriptions of the three different operation modes. If you want to set Peak or Count Mode, F6.1 must be set to 3(NONE), otherwise, Peak or Count Mode will not activate.
	1 ( Peak )	
	2 ( Counter )	
F5.2 ( Counted Item Code )	number	Specifies the item code number for the count function. Allowed numbers are 01 to 99. Refer to Section 11 for description of the setting of the counted item code.



F5.3 (Zero)	—	Sets the scale to zero calibration before inputting the total weight of the counted items. Refer to Section 5.
F5.4 (Sampling Quantity)	10 $\sqrt{v}$	Specifies the quantity of sample counted items equivalent to its total weight. Refer to Section 11.
	20	
	30	
	50	
	100	
	200	
	300	
	500	
1000		
F5.5 (Average Weight)	—	Calibrate and calculate the average weight for each sample. Refer to Section 11.

### 9.2.6 F6 ( Relay ) Menu

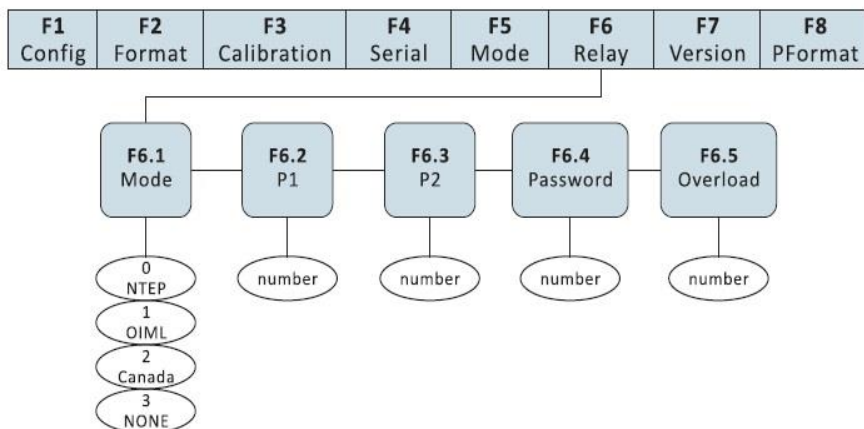

Fig. 9.2.6.1 F6(Relay) Menu

**Table 9.2.6 F6(Relay) Menu**

F6 (Relay) Menu		
Parameter	Choices	Description
Level 2 Submenu		
F6.1 (mode)	0 (NTEP) ✓	<p>For OIML, NTEP and CANADA application, Tare removal is only allowed when Gross = 0. When NONE is selected, Tare removal can be done at any weighing mode.</p> <p>For NTEP and OIML, a new Tare can be acquired even when there is a stored Tare.</p> <p>For CANADA, a new Tare can be acquired after the stored Tare is removed.</p> <p>For NONE, NTEP and CANADA, when the current weight is within the specified zero range, zero scale can be performed irrespective it is in Gross or Net mode.</p> <p>For OIML, zero scale can only be performed when it is in Gross mode and Tare can be removed when it is in Net mode.</p>
	1 (OIML)	
	2 (CANADA)	
	3 (NONE)	
F6.2 (P1) <i>This function is not available in 805BS-TN-B Lite Version model</i>	Number	Specifies the first limit to trigger the Relay 1. Refer to Section 12 for Relay Output setup.
F6.3 (P2) <i>This function is not available in 805BS-TN-B Lite Version model</i>	Number	Specifies the second limit to trigger the Relay 2. Refer to Section 12 for Relay Output setup
F6.4 (Password) <i>For 805TS-B-17, 805BS-B-17 &amp; 805BS-TN-B</i>	Number	The password is required when entering or exiting configuration mode. (refer to Section 7.2)

<p>F6.5 (User Overload) For 805TS-B-17, 805BS-B-17 &amp; 805BS-TN-B</p>	<p>Number</p>	<p>When weight exceeds user overload value, the indicator will alarm (beeping).</p>
---	---------------	---

Note: To activate the Password function, the value in F6.1 should be 3 (F6.1=3) and the value in F6.4 must not equal to zero (F6.4>00000) and keep the jumper in SW2 set to CFG.

### 9.2.7 F7 (Version) Menu

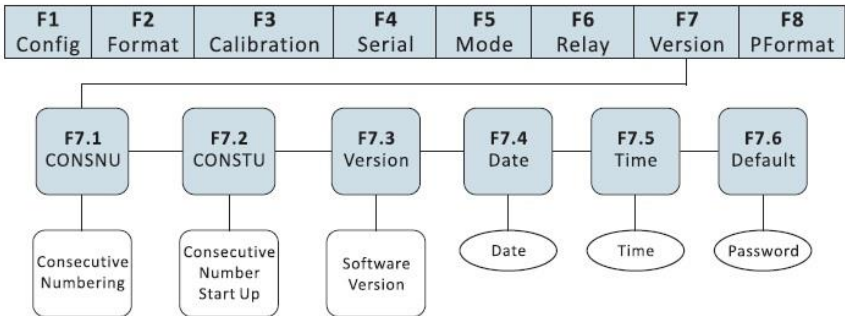



Fig. 9.2.7.1 F7(Ver) Menu

**Table 9.2.7 F7(Ver) Menu**

F7 (Ver) Menu		
Parameter	Choices	Description
Level 2 Submenu		
F7.1 (CONSNU)	Number	Consecutive Numbering. Allows sequential numbering for print operations. The consecutive number value is incremented following each print operation. The initial value of this parameter is set to the start up value specified in the CONSTU (F7.2 value). Refer to Section 13.4
F7.2 (CONSTU)	Number	Consecutive Number Start Up Value. Refer to Section 13.4

F7.3 (Version)	Soft Version	Displays the software version installed in the indicator. This value cannot be altered.
F7.4 (DATE)	Date	Format setting for the date is: "DD.MM.YY"
F7.5 (TIME)	Time	Setting of time as "HH.MM.SS"
F7.6 (Default)	Number	Press  after inputting the password to recover the default values from the ROM. Refer to Appendix 15.3.

## 9.2.8 F8 ( PFormat ) Menu

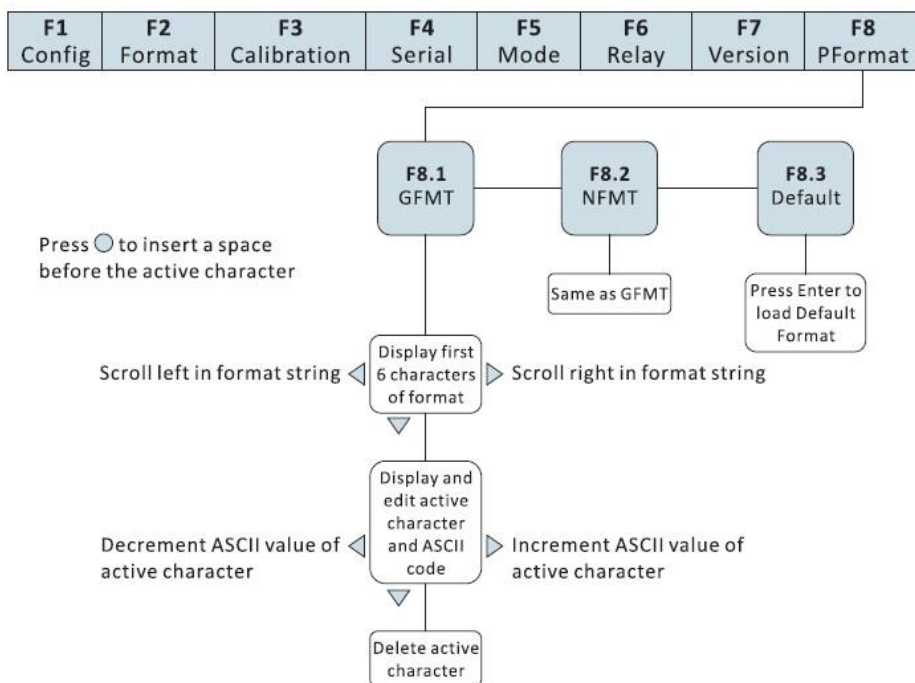

Fig. 9.2.8.1 F8 (PFormat) Menu

F8 (PFormat) Menu is used for setting Print format of serial print output. Refer to Section 13.

## 10. Calibration

The calibration of these indicators consists of the following calibration procedures:

- Zero calibration
- Providing the test weight value or known weight value
- Span calibration
- Re-zero calibration ( applicable if test weights are used with hooks or chains )

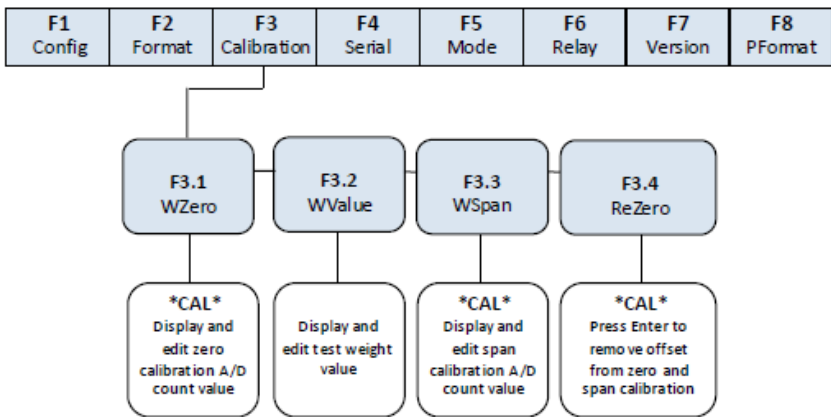









Fig. 10.1 F3(Calibration) Menu

This section describes calibration procedures for each of the calibration methods. There are two methods in calibrating the indicator:



1. **Weight Calibration** – this method will require an actual test weights or known weight to calibrate the scale and indicator
2. **Digit Calibration** – in this method the actual test weight may not be required. It requires the A/D Count for the zero, span and re-zero calibration. This method can be applicable only if you had already successfully done the Weight Calibration and recorded its A/D Count in each procedure. You are not required to load the actual test weights in the scale during span calibration.

## Weight Calibration Procedures:

*Suggestion: In conducting the Weight Calibration procedures it is recommended to record all the A/D count values generated by the indicator and the test weight value from F3.1, F3.2, F3.3 and F3.4. When certain parameters were accidentally altered, the data can be recovered by following the Digit Calibration procedures. There is no need to re-calibrate using the actual test weights.*







- 1) Move the jumper of SW2 to CFG setting to switch the indicator to Configuration mode (display will show "F1"). Remove all weights from the scale platform. If the test weights require hooks or chains, place the hooks or chains on the scale for zero calibration.
- 2) Press  until the display shows "F3". Press  to go to zero calibration mode. Display will show "F3.1".
- 3) When display shows "F3.1", press  to start zero calibration. Display is showing "CAL" while calibration is in progress. When completed, the A/D count for the zero calibration is generated. You may record this A/D count. This A/D count (usually a 6-digit count) can be used when recalibrating the indicator using the Digit Calibration Method. Do not adjust this value. Then press  again to save the zero calibration value and go to the next menu (display will show "F3.2").
- 4) When display shows "F3.2", place the test weight on the scale and press  to enter the test weight value. Follow Fig. 10.2 to input the test weight value, then press  to save the value. The indicator will go to the next menu. Display will show "F3.3".
- 5) When display shows "F3.3" (make sure the test weights are on the scale), press  to start span calibration. Display is showing "CAL" while calibration is in progress. When completed, the A/D count for the span calibration is generated. You may record this A/D count. This A/D count (usually a 6-digit count) can be used when recalibrating the indicator using the Digit Calibration Method. Do not adjust this value. Press  again to save the span calibration value and indicator will go to the next menu. Display will show "F 3.4".
- 6) F3.4 Menu is used to offset the calibration parameter values when removing the hooks or chains or any tare apparatus used during the zero and span calibration.

When display shows "F3.4", there are 2 options:

- If no other apparatus used to hang the test weights during calibration, remove the test weight and press  to return to F4 Menu. Display will show “F4”
- If the hooks or chains or any tare apparatus used during calibration will not be used for deploying the scale, remove these including the test weights from the scale. With all weights are removed, press  to re-zero the scale. This function will adjust the zero and span calibration values. Display is showing “CAL” while zero and span calibrations are adjusted. When completed, the adjusted and new A/D count for the zero calibration is generated. The new A/D count for span calibration is also generated (check at F3.3). You may record this A/D counts because these can be used when recalibrating the indicator using the Digit Calibration Method. Do not adjust these values. Press  to save the value and indicator will return to F4 Menu. Display will show “F4”.

7) Move back the jumper of SW2 to DFT to exit from Calibration mode.

**Digit Calibration Procedures:**

- 1) Move the jumper of SW2 to CFG setting to switch the indicator to Configuration mode (display will show “F1”).
- 2) Press  until the display shows “F3” (see Fig. 10.2). Press  to go to zero calibration mode. Display will show “F3.1”.
- 3) When display shows “F3.1”, press  to show and enter the A/D count value for zero calibration. This A/D count 6-digit value must be the zero calibration A/D count value from your previous calibrated scale. When done, press  to save and indicator will go to the next menu. Display will show “F3.2”. Note, in this method the settings in F2.1, F2.2 & F2.3 must be the same from the previous scale settings.
- 4) When display shows “F3.2” (in this stage test weigh may not be required), press  to show and enter the test weight value. The test weight value here must be the same value from your previous calibrated scale. Press  to save the value and indicator will go to the next menu. Display will show “F3.3”.
- 5) When display shows “F3.3”, press  to show and enter the A/D count value for span calibration. This A/D count 6-digit value must be the span

calibration A/D count value from your previous calibrated scale. When done, press  to save and indicator will go to the next menu. Display will show "F3.4".

- 6) F3.4 is not applicable in digit calibration so press  to skip this stage. Display will show "F4". Recalibration is done.
- 7) Move back the jumper of SW2 to DFT to exit from Calibration mode.

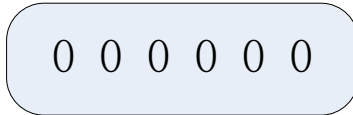





Fig. 10.2 Editing Procedure for Numerical Values

When editing numerical values, press ,  to change the digit selected. Press ,  to increase or decrease the value of the selected digit.

### 11. Counted Items Average Weight Setup

When Count mode is activated in F5.1 Menu, it is required to set up the average weight of the counted items. The indicator can save up to 100 count settings. The count items setup consists of the following procedures:

- Item code
- Zero scale
- Sample quantity
- Confirming Counted Items Average Weight



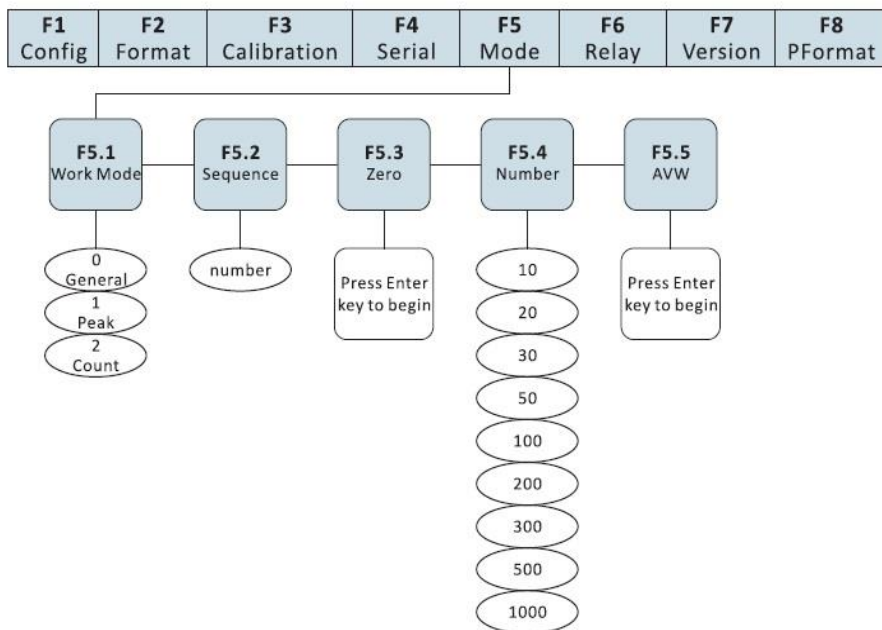











Fig. 11.1 Count Items Average Weight Setup Menu

Setup procedures are as follows:

- (1) Move the jumper of SW2 to CFG setting to switch the indicator to Configuration mode (display will show “F1”).
- (2) Press until display shows “F5” (see Fig 11.1). Press to enter F5.1. Press then press until F5.1 = 2. Press to save the value.
- (3) Press key when display shows “F5.2”. Enter your desired item code for this counted items average weight settings that we are going to set. The code number will be saved in the memory and will correspond to this counted items average weight settings. The code numbers are from 01 to 99. Previously saved settings will be overwritten if you enter the same code. The code “00” is reserved for Fast Setup of Counted Items Average Weight ( refer to Section 7.5.8 ). Follow the procedures in Fig. 10.2 to input and edit the code number. Press to save the code number and proceed to the next menu. The display will show “F5.3”.
- (4) Remove all the weight from the scale platform when display shows “F5.3”. Press to start zero calibration. Display is showing “CAL”







while processing the zero operation. When completed, display will show “F5.4”

- (5) Press  when display shows “F5.4”. Specify the sampling quantity for the total weight of counted items. Use ,  keys to specify the sampling quantity. Place the samples or the total weight that corresponds to the sampling quantity, in the platform of the scale. The quantity of the samples must be the same with what you specified in the sampling quantity. Press  to proceed to the next menu. Display will show “F5.5”.
  
- (6) Press  when display shows “F5.5”. Display is showing “CAL” while processing the average weight settings. When completed, there are two (2) possible outcomes :
  - The average weight is too small and display will show “—E5—”. Press  to return to F5.5. There are two options :
    - Combine a few small items as one sample. Change the sampling quantity that corresponds to the number of samples in F5.4 Menu. Press  to perform the average weight calculation.
    - Press  to cancel average weight setting and return to F5 Menu. Display will show “F5”.
  - When the calibration is completed the display will return to F5.2 Menu.
  
- (7) There are 2 options when display shows “F5.2”.
  - Repeat (3) to (6) if you want to set and save another counted items average weight settings.
  - Press  to return to F5 Menu to finish the set up.
  
- (8) Move back the jumper of SW2 to DFT to exit from Configurations mode.
  
- (9) At the Weighing Mode, press **【PRINT】** to open and enter the Item Code you want to activate for the counting. The item code shall be the number you saved during count calibration that corresponds to your desired counted items average weight settings. The code “00” will return the indicator to “Fast Setup of Count Items Average Weight” (refer to Section 7.3.8). Press **【UNITS】** in switching from Count Mode to Normal Weighing Mode.

## 12. Relay Output Setup

There are two relay signal outputs in the Relay function. When the weight value is smaller than the weight value set in F6.2, the Relay output 1 will trigger on while Relay output 2 is off or open. When the weight value is between the weight values setting in F6.2 and F6.3, both relay outputs are off or open. When weight value is greater than the weight value set in F6.3, the Relay output 2 will trigger on while the Relay output 1 is off or open. See Fig. 12.2 for more details.

Setup procedure:

- (1) Move the jumper of SW2 to CFG setting to switch the indicator to Configuration mode (display will show “F1”).
- (2) Press  until display shows “F6” (see Fig. 12.1). Press  to go to the Relay Output Menu. Display will show “F6.1”.
- (3) When the display shows “F6.1”, press  to go to the F6.2 Menu.
- (4) When display shows “F6.2”, press  to enter the value for the Relay 1 setting output. When completed, press  to store the value and indicator will go to F6.3 Menu.
- (5) When display shows “F6.3”, press  to enter the value for the Relay 2 setting output. When completed, press  to store the value and indicator will go to F6.4 menu.
- (6) Move back the jumper of SW2 to DFT to exit from Configurations mode.

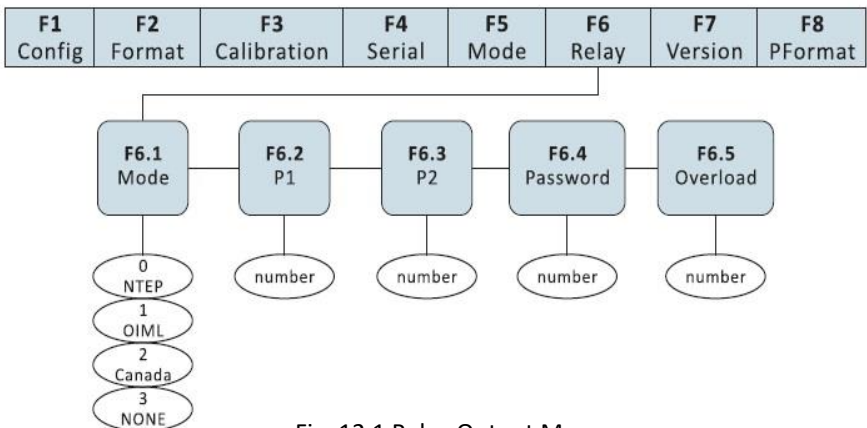

Fig. 12.1 Relay Output Menu

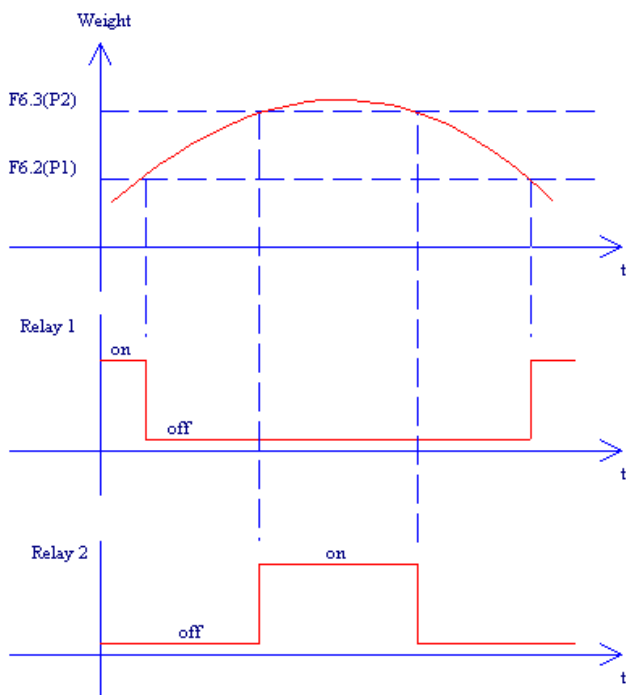

Fig. 12.2 Relay Output-Upper and Lower Values

*Note 1: Must ensure F6.3 (P2) value > F6.2 (P1) value to give proper relay outputs*

*Note 2: Weight value is in net weight and is according to the unit in F2.1 setting (Refer to F2 Menu in Section 9.2.2).*

### 13. Print Format

2 print formats via the serial port output

- Gross weight print format
- Net weight print format

After configuring the print format for GFMT and NMFT in F8.1 and F8.2, press **【PRINT】** to print the desired output.

When a tare weight is stored, the NFMT format is the printing output, otherwise, the GFMT format will be the printing output.

### 13.1 Print Format Commands

Print format commands are as shown in Table 13.1. Commands included in the format strings must be enclosed between < > delimiters. Any characters outside of the delimiters are printed as text on the ticket. Text characters can include any ASCII character shown in Appendices. The maximum number of characters that can be input into each print format is 250.

Table 13.1 Print Format Commands

Command	Description
<G>	Gross weight in displayed units. The format is "XXXXXXX UU" where "XXXXXXX" is the weight and "UU" is the unit
<N>	Net weight in displayed units. Same format as in <G> command
<T>	Tare weight in displayed units. Same format as in <G> command.
<CN>	Consecutive number. The Format is "XXXXXX". See Section 13.1. For print consecutive number setting.
<CD>	Count item code (must set count code first). The format is "XX". See Section 7.5.6 for count item code setting.
<CO>	Count item quantity (must set count quantity first). The format is "XXXXX".
<D>	Date of printing. Format: dd-mm-yy, where dd is the day, mm is the month and yy is the year.
<I>	Time of printing. Format: HH:MM:SS, where HH is the hour, MM is the minute and SS is the second.
<P>	Peak mode value (used only when Peak Mode is set). The format is "XXXXXXX" (including decimal point)
<NLnn>	New line (nn is the number for CR and LF. Value must be in the range 01-99. If nn is not specified, 01 is assumed).
<SPnn>	Space (nn=number of space. Value must be in the range 01-99. If nn is not specified, 01 is assumed).
<E>	Command to complete print format setting. If a command is not ended with the <E> command, indicator is operated without print mode.

When indicator is set to Default Format String, the Table 13.2 shows the default print format of both GFMT and NFMT.

Table 13.2 Default Print Format

Format	Default Format String	Sample Output
GFMT	<G>GROSS<NL>	1564.23 LB GROSS
NFMT	<G>GROSS<NL> <T>TARE<NL> <N>NET<NL>	4567.2 LB GROSS 23.5 LB TARE 4543.7 LB NET

### 13.2 GFMT and NFMT Print Format Input

Setting of GFMT and NFMT is as follows:

F1	F2	F3	F4	F5	F6	F7	F8
Config	Format	Calibration	Serial	Mode	Relay	Version	PFormat

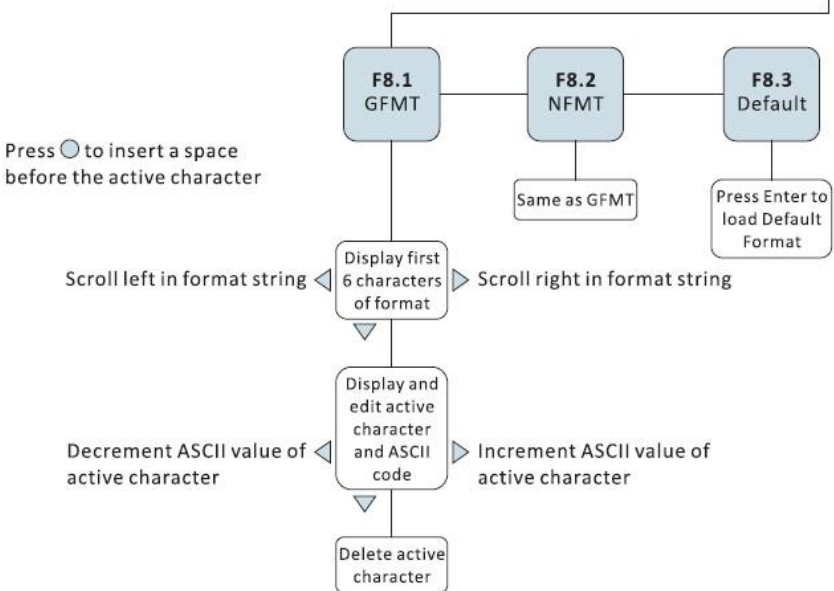























Fig. 13.2.1 Print Format Input Flow Diagram

- (1) Move the jumper of SW2 to CFG setting to switch the indicator to Configurations mode (display will show "F1").
- (2) Press  multiple times until it reach to "F8" (see Fig. 13.2.1). Press  to Print Format Menu and will show "F 8.1".
- (3) When display shows "F8.1", press  again and display shall show the default or programmed printing format string of GFMT. When format string is not showing, we need to load the defaults using the F8.3 menu. Go to F8.3 then press the tare key. It will display "SET ?". Press the tare key again to confirm to load the default formats.
- (4) Use ,  to move the cursor in highlighting the character of the printing format string. Once character is highlighted it will be flashing.
- (5) To insert character between two characters, highlight the character at the right then press  to add a space. Once a space is added at the left, press  to insert a character value.
- (6) To edit a character in the string, highlight the character by moving the cursor into it then press . Use  or  to select the decimal equivalent for the ASCII character. Refer to ASCII Codes Table at Appendices section 15.5. Once the decimal equivalent is selected for the character, press  to return to the string.
- (7) To delete a character in the string, highlight the character by moving the cursor into it then press . It will show the decimal equivalent value. Press the  again and it will return to the string and the character selected is deleted.
- (8) Once the printing format string in F8.1 (GFMT) is completed, press  to go to F8.2 (NFMT) then press  to open the NFMT printing format string. Follow the instructions above starting from step # 4 to step # 7 in inputting the commands for the printing format.
- (9) Here is a sample printing format string: <G>Gross<nL><E>. Refer to Table 13.1 Print Format Commands for the detailed guides of print commands. Remember always to place the <E> command of your string otherwise it will not get operational.
- (10) Once the programming is done, move back the jumper of SW2 to DFT to exit from Configurations mode then press the print key to print the programmed data.

### 13.3 Default Formatting

- (1) Move the jumper of SW2 to CFG setting to switch the indicator to Configurations mode (display will show “F1”).
- (2) Press  multiple times until display shows “F8” (see Fig. 13.2.1). Press  to go to Print output menu and display will show “F8.1”.
- (3) When display shows “F8.1”, press  twice until display shows “F8.3”.
- (4) Press  and display will show “Set?”. There are 2 options:
  - Pressing the  key will change the GFMT and NFMT format characters to default settings (see Table 13.2), and then return to F8 Menu. Note, all of the commands added in the print format string will be erased and replaced by default settings.
  - Pressing the  key will cancel the default formatting and will return to F8 menu.
- (5) Move back the jumper of SW2 to DFT to exit from Configurations mode

### 13.4 Printing Consecutive Number

Setting the printing consecutive number can be set at F7.1 Menu (CONSNU). The consecutive number value will increment by 1 upon each print operation. The start up number can be set at F7.2. The parameter value in F7.2 will be the initial for the consecutive number. Refer to F7.1 Menu and F7.2 Menu for details.

Detailed Setup Procedure:

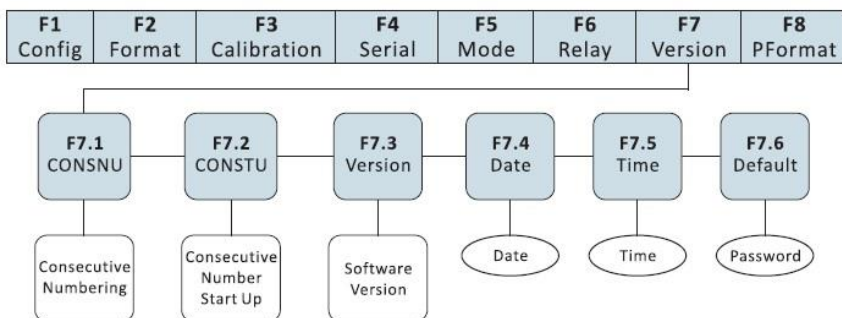















Fig. 13.4 Consecutive Numbering Setup



- (1) Move the jumper of SW2 to CFG setting to switch the indicator to Configurations mode (display will show “F1”).
- (2) Press  multiple times until display shows “F7” (see Fig. 13.2.1). Press  to go to F7.1 Menu.
- (3) When display shows “F 7.1”, press  again. The display will show the current consecutive number “000000”. Edit numbers according to Fig. 10.2. After editing, press  to go to F7.2 Menu.
- (4) When display shows “F7.2”, press  and display will show “000000”. Edit numbers according to Fig. 10.2. After editing, press  to go to the next menu. Display will show “F7.3”.
- (5) Move back the jumper of SW2 to DFT to exit from Configurations mode.

### **13.5 Date and Time Setting**

- (1) Switch the indicator into Configurations mode.
- (2) Press  multiple times until display shows “F7”. Press  to go to F7.1 Menu then press  to go to F7.4.
- (3) When display shows “F7.4” (see Fig. 13.4). Press  to enter into Date setup mode and display will show like “00.00.00”. The date format is “DD.MM.YY”.
- (4) When date setup is completed, press  to save settings and display will show F7.5.
- (5) When display shows “F7.5”, press  to enter into time setup mode and display will show like “00.00.00”. The time format is “HH.MM.SS”.
- (6) When completed, press  to save settings and display will go to F7.6 Menu.
- (7) Move back the jumper of SW2 to DFT to exit from Configurations mode.

## 14. Serial Communication

Indicator has two serial communication modes:

- Continuous transmission
- Transmission upon request (from an external PC)

Setting up of Baud Rate, No. of Bits, Parity, Transmission Mode and serial address can be set in F4 Menu.

Detailed Setup Procedure is as follows:

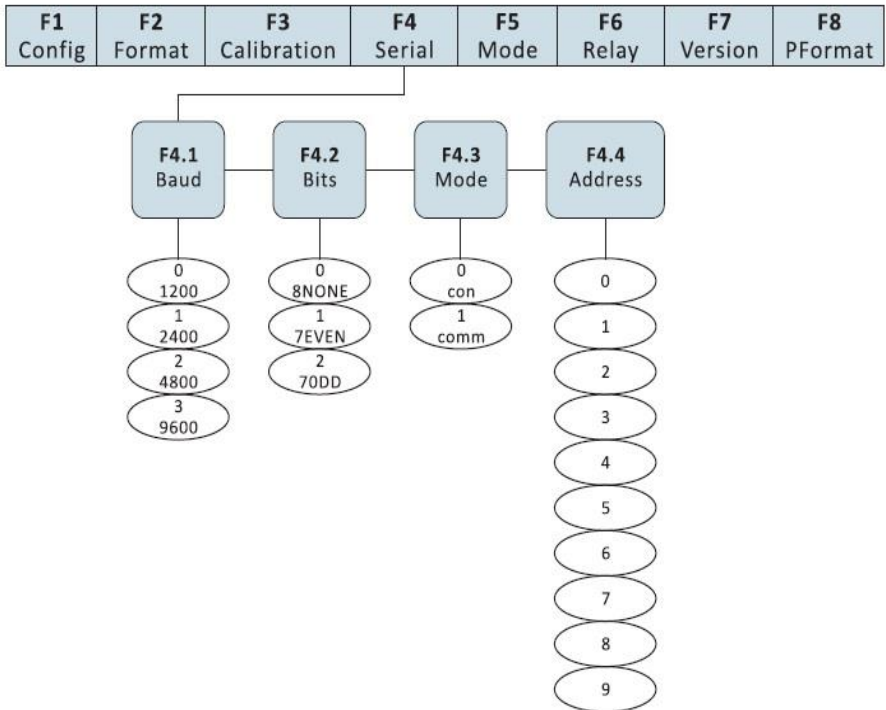

Fig. 14.1 Serial Communication Menu



### 14.2.1 Data Transmission Sequence

Transmission Format from PC:

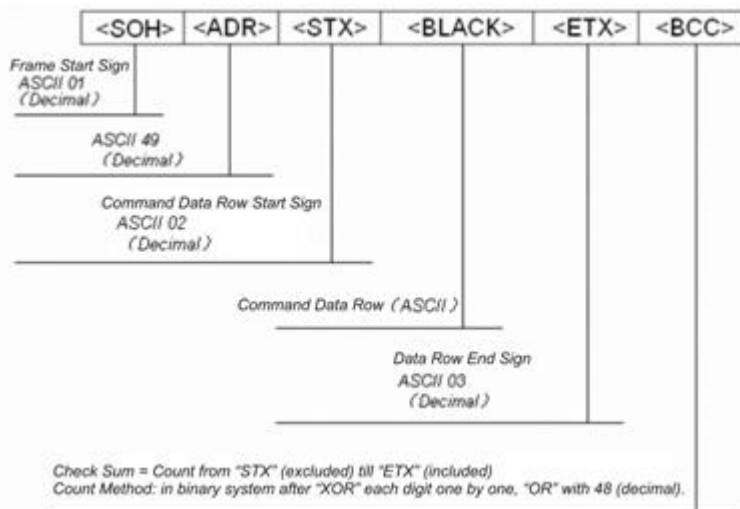

Fig. 14.2.1 Transmission Format from PC

Example: Set BLACK to "G" (which is 47H) in ASCII code. Inspection and BCC calculation are as follow:

ASCII	HEX	BCC	
G	47H	47H	
ETX	03H	44H	
	30H	74H	"OR" with 30H

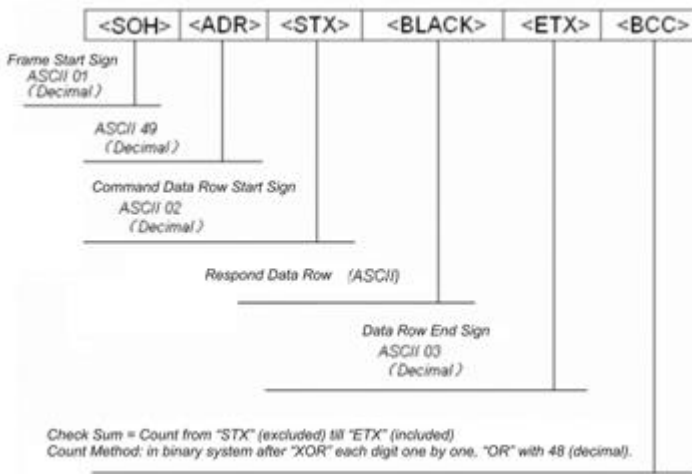

Fig. 14.2.2 Respond Format from Indicator

## 14.2.2 Communication Command

### 14.2.2.1 Transmit Current Weight Value

Command data from PC<BLACK> Format: G (ASCII 71)

Response data from indicator<BLACK> Format see Fig. 14.2.2.1

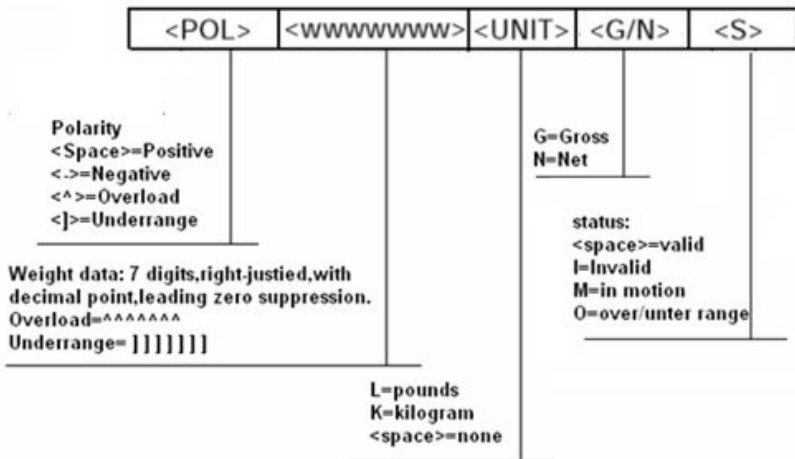

Fig. 14.2.2.1 Respond to<BLACK>data after receiving G command

Example: PC receives data from indicator

PC sends: 01H, 31H, 02H, **47H**, 03H, 74H

Indicator responds: 01H, 31H, 02H, **20H, 20H, 20H, 20H, 31H, 30H, 37H, 32H, 4BH, 47H, 20H**, 03H, 3BH

Data received in gross weight 1072kg.

*Note: The Hex value of <ADR> must coincide with the value of serial address in F4.4. If serial address is F4.4=1 then <ADR> must be 31H. Similarly, if F4.4=5 then <ADR> must be 35H.*

#### **14.2.2.2 Zero Scale**

PC command data <BLACK> format: Z (ASCII 90)

Indicator receives correctly and responds data <BLACK> =“OK”

Example: PC sends command to indicator to zero scale

PC sends: 01H, 31H, 02H, **5AH**, 03H, 79H

Indicator responds: 01H, 31H, 02H, **4FH, 4BH**, 03H, 37H

## 15. Appendices

### 15.1 Error Messages

Error Message	Description	Solution
-- E 0 --	Data too big after changing units	Check decimal setting in primary and secondary units. Refer Section 9.2.2 regarding F2 Menu
-- E 1 --	Incorrect operating parameters	Check parameters according to Section 9
-- E 2 --	A/D exchange error S	Check hardware by qualified personnel
-- E 3 --	Data reading error	Check hardware by qualified personnel
-- E 4 --	A/D transfer start up error	Check hardware by qualified personnel
-- E 5 --	Counted items average weight too small	Check scale range or increase sampling weight according to Section 11
-- E 6 --	No average weight set for count items	Refer to Section 11 to set average weight
-- E 7 --	Load cell input signal > 20mV	Check load cell and connecting cables
-- EL --	Load cell input signal < -4mV	Check load cell and connecting cables
-- OF --	Load value > F1.5 Set value	Lessen load on scale

### 15.2 Software Version and Default Configuration Parameters

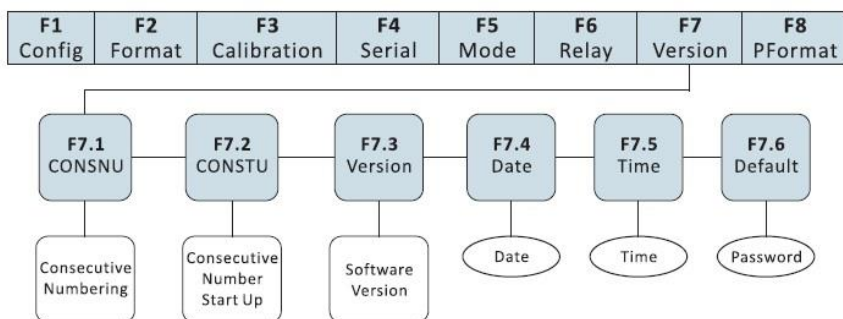















Fig. 15.2.1 F7(Ver) Menu

### 15.2.1 Find out the indicator software version

- (1) Move the jumper of SW2 to CFG setting to switch the indicator to Configurations mode (display will show "F1").
- (2) Press  multiple times until display shows "F7" (see Fig. 15.2.1). Press  to go to "F 7.1" then press  twice until display shows "F7.3".
- (3) When indicator shows "F7.3", press  again, the display will show the current software version like "3.21". Software version cannot be edited.
- (4) Press  to return to main menu.
- (5) Move back the jumper of SW2 to DFT to exit from Configurations mode.

### 15.2.2 Restore Factory Setup Parameters (Default Configuration Parameters)

- (1) Move the jumper of SW2 to CFG setting to switch the indicator to Configurations mode (display will show "F1").
- (2) Press  multiple times until display shows "F7" (see Fig. 15.2.1). Press  to go to "F7.1" then press  multiple times until display shows "F7.6".
- (3) When display shows "F7.6", press . The indicator will ask the 4-digit code to restore the settings to default. The 4-digit code is "0711".
- (4) When the 4-digit code is incorrect, the display will show "Err".
  - Press  to display again the 4-digit code dialog.
  - Press  to go back to main menu.
- (5) When the correct 4-digit code is entered, the indicator will display "Set?" There are 2 options:
  - Pressing the  will proceed to erase the current settings and restore to its default settings. The indicator will return to "F7.1".
  - Pressing the  will cancel the restore operation and will return to main menu. The current settings are not erased.
- (6) Move back the jumper of SW2 to DFT to exit from Configurations mode.



### 15.3 Technical Specifications

Specifications	805TS Series		805BS Series	
	805TS-B-17		805BS-B-17	805BS-TN-B Lite Version
A/D Sampling Rate	7.5 times/sec~960times/sec selectable			
Update Rate	50Hz or 20ms			
Internal Resolution	24 bits			
Non-linearity	≤0.005%F.S			
Zero return	≤0.1μV/ °C			
Temperature Effect	≤5ppm/°C			
Range of Input Signal	2~20mV			
Range of Scale Initial Signal	-1~+9mV			
Input Signal Sensitivity	0.2uV/d (minimum) 1.5uV/d (recommended)			
Zero Scale Range	±1.9%FS、±100%FS selectable			
Tare Range	0 ~ +100%FS			
Operating Temperature	-10°C ~ 40°C			
Operating Humidity	≤ 90% (without dew)			
Power Supply/ Adaptor	Input : 120VAC, 60Hz, 110mA Output : 9VDC 600mA		Input 120VAC 60HZ 110mA; Output 12VDC 400mA	
Relay Outputs	Up to 28VDC (2A) & up to 240VAC (1A)			
Load Cell Bridge Voltage	DC 5V can be connected to 16 cells of not less than 700Ω or 8 cells of not less than 350Ω			

15.4 ASCII Codes Table

ASCII	Dec	Hex	ASCII	Dec	Hex	ASCII	Dec	Hex
space	32	20	@	64	40	'	96	60
!	33	21	A	65	41	a	97	61
"	34	22	B	66	42	b	98	62
#	35	23	C	67	43	c	99	63
\$	36	24	D	68	44	d	100	64
%	37	25	E	69	45	e	101	65
&	38	26	F	70	46	f	102	66
'	39	27	G	71	47	g	103	67
(	40	28	H	72	48	h	104	68
)	41	29	I	73	49	i	105	69
*	42	2A	J	74	4A	j	106	6A
+	43	2B	K	75	4B	k	107	6B
,	44	2C	L	76	4C	l	108	6C
-	45	2D	M	77	4D	m	109	6D
.	46	2E	N	78	4E	n	110	6E
/	47	2F	O	79	4F	o	111	6F
0	48	30	P	80	50	p	112	70
1	49	31	Q	81	51	q	113	71
2	50	32	R	82	52	r	114	72
3	51	33	S	83	53	s	115	73
4	52	34	T	84	54	t	116	74
5	53	35	U	85	55	u	117	75
6	54	36	V	86	56	v	118	76
7	55	37	W	87	57	w	119	77
8	56	38	X	88	58	x	120	78
9	57	39	Y	89	59	y	121	79
:	58	3A	Z	90	5A	z	122	7A
;	59	3B	[	91	5B	{	123	7B
<	60	3C	\	92	5C		124	7C
=	61	3D	]	93	5D	}	125	7D
>	62	3E	^	94	5E	~	126	7E
?	63	3F	_	95	5F	DEL	127	7F

15.5 Indicator Display Character

!	-	9	E	Q
“	. .	:	F	R
#	/	;	G	S
\$	0	<	H	T
%	1	=	I	U
&	2	>	J	V
'	3	?	K	W
(	4	@	L	X
)	5	A	M	Y
*	6	B	N	Z
+	7	C	O	[
,	8	D	P	\

**ANYLOAD Weigh & Measure Inc.**

Website: [www.anyload.com](http://www.anyload.com)

Email: [info@anyload.com](mailto:info@anyload.com)

Fax: +1 866 612 9088

North America Toll Free: 1-855-ANYLOAD (269 5623)