

# 106KS

## Stainless Steel

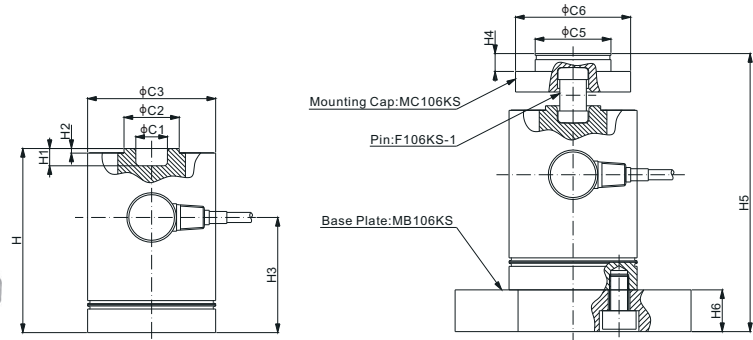

Mounting Cap: MC106KS  
Pin: F106KS-1  
Base Plate: MB106KS

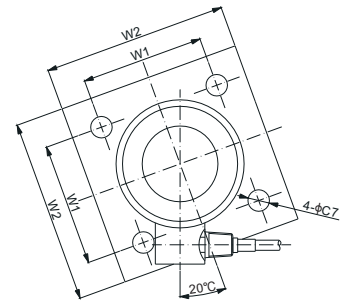
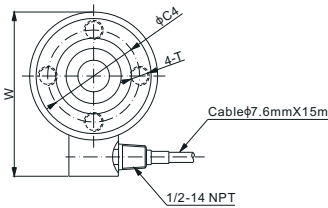

- Material of MC106KS & F106KS-1 is 17-4PH stainless steel;  
- Material of MB106KS is 304 stainless steel



Mounting hardware to be ordered separately.

### DIMENSIONS

RATED CAPACITY	C1	C2	C3	C4	C5	C6	C7	H	H1	H2	H3	H4	H5	H6	W	W1	W2	T
<b>Klb/inches</b>																		
50	1.03	1.80	4.17	3.00	2.47	3.75	0.70	6.00	0.56	0.15	3.75	0.58	9.70	2.00	5.35	4.00	6.00	5/8-18 UNF Depth13
100	1.54	2.28	5.51	4.00	2.70	3.75	0.82	8.12	0.83	0.20	4.84	0.58	12.71	2.00	6.69	6.00	8.00	3/4-16 UNF Depth20
<b>kg/mm</b> (conversion of above dimensions)																		
22,679.6	26.2	45.7	106.0	76.2	62.7	95.3	17.8	152.4	14.3	3.8	95.3	14.8	246.4	50.8	136.0	101.6	152.4	5/8-18 UNF Depth0.5
45,359.2	39.0	57.9	140.0	101.6	68.6	95.3	20.8	206.2	21.0	5.1	123.0	14.8	322.8	50.8	170.0	152.4	203.2	3/4-16 UNF Depth0.8

SPECIFICATIONS			
Full Scale Output	2.0 mV/V ± 0.25%	Recommended Excitation	10V (15V Maximum)
Zero Balance	± 0.02 mV/V	Insulation Resistance	>2 [ 50V DC ] GΩ
Non-linearity	< ± 0.050%	Compensated Temperature Range	-10°C to 50°C / 14°F to 122°F
Repeatability	< ± 0.010%	Safe Overload	150% of full scale
Hysteresis Error	< ± 0.060%	Breaking Overload	300% of full scale
Creep in 30 min.	< ± 0.030%	Seal Type / IP Rating	Welded Seal / IP68
Input Resistance	700Ω ± 20	Cable Color Code	Exc+ Red      Exc- Black
Output Resistance	700Ω ± 5		Sig+ Green    Sig- White
Element Material	17-4PH Stainless Steel		Shield Bare

### PART NUMBER\*

Load Cell	Rated Capacity	Part No.	Weight (kg) Approx.
50Klb.....	106KS-50Klb.....	6.3	
100Klb.....	106KS-100Klb.....	13.4	
Mounting Hardware	Load Cell Capacity	Part No.	Weight (kg) Approx.
Mounting Cap.....	50Klb.....	MC106KS-50Klb.....	-
	100Klb.....	MC106KS-100Klb.....	1.2
Pin.....	50Klb.....	F106KS-1-50Klb.....	-
	100Klb.....	F106KS-1-100Klb.....	0.5
Base Plate.....	50Klb.....	MB106KS-50Klb.....	-
	100Klb.....	MB106KS-100Klb.....	15.2

### INTERCHANGEABLE REFERENCE

Manufacturer	Model
Coti Global.....	CG-CC22
Mettler-Toledo.....	B10883600A
Mettler-Toledo.....	B10887700A
Totalcomp.....	T752

\* ATEX, FM, IECEx approved versions carry the "-Ex" suffix.