

Alloy Steel, Patent Design, Mounting Hardware For 276EH Load Cell  
F266-1

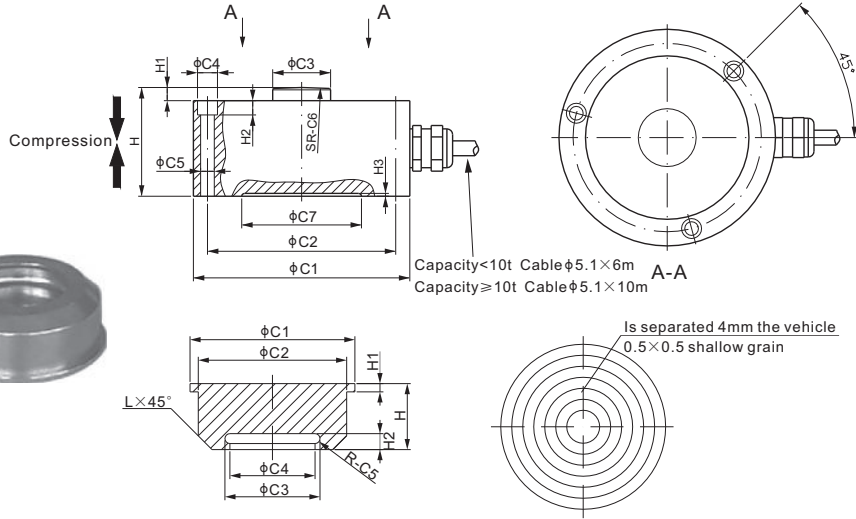

Mounting hardware included.

DIMENSIONS

RATED CAPACITY	C1	C2	C3	C4	C5	C6	C7	H	H1	H2	H3
<b>t/mm</b>											
5	60.0	52.0	9.5	6.0	3.2	30.0	42.0	24.0	4.0	3.0	0.8
10	63.6	55.0	13.5	7.2	4.2	100.0	44.0	26.0	4.0	5.0	0.8
25	75.9	66.0	20.3	7.0	4.8	150.0	54.0	38.1	4.6	5.0	1.0
50	105.0	90.0	30.0	11.0	6.5	250.0	76.0	53.0	7.0	7.0	1.0
100	123.0	98.0	43.0	15.0	10.5	380.0	74.0	95.0	15.0	12.0	1.0
<b>lb/inches</b> (conversion of above dimensions)											
11,023.1	2.36	2.05	0.37	0.24	0.13	1.18	1.65	0.94	0.16	0.11	0.03
22,046.2	2.50	2.17	0.53	0.28	0.17	3.94	1.73	1.02	0.16	0.20	0.03
55,115.6	2.99	2.60	0.80	0.28	0.19	5.91	2.13	1.50	0.18	0.20	0.04
110,231.1	4.13	3.54	1.18	0.43	0.28	9.84	2.99	2.09	0.28	0.28	0.04
220,462.3	4.84	3.86	1.69	0.59	0.41	14.96	2.92	3.74	0.59	0.47	0.04
<b>PART NUMBER</b>											
<b>LOAD CELL CAPACITY</b>											
<b>C1</b>											
<b>C2</b>											
<b>C3</b>											
<b>C4</b>											
<b>C5</b>											
<b>H</b>											
<b>H1</b>											
<b>H2</b>											
<b>L</b>											
<b>Weight (kg) Approx.</b>											
<b>t/mm</b>											
F266-1A	5	33.0	27.0	12.0	10.0	1.0	13.0	3.0	2.9	3.0	0.06
F266-1B	10	41.0	35.0	16.0	14.0	1.0	16.0	3.0	2.9	4.0	0.12
F266-1C	25	49.0	43.0	23.8	21.0	1.4	19.0	3.0	3.9	5.0	0.20
F266-1E	50	72.0	66.0	34.6	31.0	1.8	36.0	3.0	5.7	5.0	-
F266-1F	100	80.0	74.0	55.0	45.0	5.0	50.0	3.0	12.4	7.0	-
<b>lb/inches</b> (conversion of above dimensions)											
F266-1A	11,023.1	1.30	1.06	0.47	0.39	0.04	0.51	0.12	0.11	0.12	0.06
F266-1B	22,046.2	1.61	1.38	0.63	0.55	0.04	0.63	0.12	0.11	0.16	0.12
F266-1C	55,115.6	1.93	1.69	0.94	0.83	0.06	0.75	0.12	0.15	0.20	0.20
F266-1E	110,231.1	2.83	2.60	1.36	1.22	0.07	1.42	0.12	0.22	0.20	-
F266-1F	220,462.3	3.15	2.91	2.17	1.77	0.20	1.97	0.12	0.49	0.28	-

SPECIFICATIONS

<b>Full Scale Output</b>	2.5 mV/V ± 10%	<b>Recommended Excitation</b>	10V (15V Maximum)
<b>Zero Balance</b>	± 0.02 mV/V	<b>Insulation Resistance</b>	>2 [ 50V DC ] GΩ
<b>Non-linearity</b>	Cap. ≤ 50t: < ± 0.32%; Cap. ≥ 100t: < ± 1%	<b>Compensated Temperature Range</b>	-10°C to 50°C / 14°F to 122°F
<b>Repeatability</b>	Cap. ≤ 50t: < ± 0.050%; Cap. ≥ 100t: < ± 0.2%	<b>Safe Overload</b>	150% of full scale
<b>Hysteresis Error</b>	Cap. ≤ 50t: < ± 0.32%; Cap. ≥ 100t: < ± 2%	<b>Breaking Overload</b>	300% of full scale
<b>Creep in 30 min.</b>	Cap. ≤ 50t: < ± 0.10%; Cap. ≥ 100t: < ± 0.1%	<b>Seal Type / IP Rating</b>	Environmentally Sealed / IP67
<b>Input Resistance</b>	400Ω ± 20	<b>Cable Color Code</b>	Exc+ Red      Exc- Black Sig+ Green    Sig- White Shield Bare
<b>Output Resistance</b>	350Ω ± 3		
<b>Element Material</b>	Alloy Steel, Nickel Plated		

PART NUMBER\*

Rated Capacity	Part No.	Weight (kg) Approx.
5t.....	276EH-5t.....	0.6
10t.....	276EH-10t.....	0.9
25t.....	276EH-25t.....	1.8
50t.....	276EH-50t.....	4.2
100t.....	276EH-100t.....	8.7

WEIGH MODULE

Model	Page
276EHM1 .....	139

\* ATEX, FM, IECEx approved versions carry the "-Ex" suffix.