



1-855-269-5623
www.anyload.com

V1.0.2

TECHNICAL MANUAL

© ANYLOAD Weigh & Measure Inc. All rights reserved.

ANYLOAD® is a registered trademark of ANYLOAD Weigh & Measure Inc. All other brand or product names mentioned in this document are trademarks or registered trademarks of their respective owners.

All information contained in this document is, to the best of our knowledge, complete and accurate at the time of publication. ANYLOAD Weigh & Measure Inc. reserves the right to make changes to the technology, features, specifications, and design of its equipment without prior notice.

The most current version of this document, along with any software, firmware, and other product updates, can be found on our website:

www.anyload.com

Legal Notice

ANYLOAD products are subject to our Standard Terms and Conditions of Sale, Warranty Policy, and applicable regulatory compliance requirements as they may be updated without notice. It is the user's responsibility to ensure proper installation, operation, and maintenance of the equipment as outlined in this manual and in accordance with all relevant laws and standards.

ANYLOAD Weigh & Measure Inc. disclaims all warranties not expressly stated in the Warranty Policy, including but not limited to implied warranties of merchantability and fitness for a particular purpose. ANYLOAD shall not be liable for any direct, indirect, incidental, or consequential damages arising from the use or inability to use this equipment.

CONTENTS

CONTENTS	1
1. Specifications	4
2. Front Panel Layout	5
3. Connections	6
4. Installation	7
4.1 Wiring Instructions	7
4.2 Power Connection.....	8
4.3 Load Cell Connection	8
5. Configurations	9
5.1 Supervisor Mode.....	9
5.2 Physical Load Calibration	10
5.3 Digital Calibration	12
5.4 Gravity Compensation.....	14
5.5 Modifying Calibration.....	15
5.6 Maintenance	17
5.7 Weight Compensation.....	20
5.8 Settings Mode	21
5.8.1 User Interface	21
5.9 Parameters	23
5.10 Serial Bus	26
5.11 Print & Save.....	28
5.12 Comparator	30
5.14 Comparator Setting.....	40
5.15 Ethernet	41
6. Serial Interface	44
6.1 Serial Connection.....	44
6.2 Serial Format.....	45
6.3 Command Mode.....	47
7. External I/O Comparator	51
7.1 External Input.....	51
7.2 External Output.....	51
8. ModBus-RTU	52

9. ModBus-TCP 56
 9.1 ModBus-TCP frame structure 56
10. Error Messages 57

Revision History:

Record with brief description of all revisions made to product or manual

Version	Date	Description
1.0.0	June 13th, 2025	First public release version.
1.0.1	August 13th, 2025	Removed "Anyload 2" string format
1.0.2	August 14th, 2025	Fixed table rendering issue

The most current version of this document, along with any software, firmware, and other product updates, can be found on our website:

www.anyload.com

1. Specifications

Case Material	ABS
Display	3.46" Full Color IPS TFT LCD with Resistive Touch Panel
ADC Resolution	24bits
ADC Conversion Rate	5,000Hz
Sensor Voltage	5VDC (Up to 8 when applying 350Ω)
Sensitivity & Range	0.1uV/D, 0~39mV (-19.5~19.5mV)
External Input / External Output	4 contact photo-coupler 4 open collectors (AC/DC 350V, 120mA)
Serial Interface	RS-232
Power	18-36 VDC, 5W
Operating Temperature	-20°C ~ 60°C / -4°F ~ 140°F
Operating Humidity	85% R.H. (no condensation)
Product Weight	0.16kg

2. Front Panel Layout



No	Name	Descriptions
1	Comparator Mode	Displays the name of the selected comparator mode.
2	Internet	Displays an icon for the selected option: Ethernet or Wi-Fi.
3	Bluetooth	If Bluetooth is enabled, an icon will appear.
4	Set-Point Code	Displays the SP code where the comparator mode is stored. If you press [SP], you can edit the set-point code and comparator mode's setting values.
5	Status Lamps	Displays the status of the measuring value by the lamp.
6	Ext. Input Signal	Displays the external input operation status.
7	Measuring Value	Displays measurement values in real time.
8	Date & Time	Displays the current date & time
9	Comparator Signal	Displays 4 open collector output states and values.
10	Weight Comp. Lamp	When the weight compensation function is used, the weight compensation lamp is displayed on the screen.
11	Stable Lamp	The stable state of the measured weight is indicated by a lamp.
12	Display Unit	Displays the unit of measuring value. If the unit is calibrated in N, kgF, or Nm, kgF*m, it is converted and displayed in a convertible unit by pressing [Unit].
13	Key Switch Name	If tactile switch operation is required, the name of the corresponding key is displayed.

3. Connections

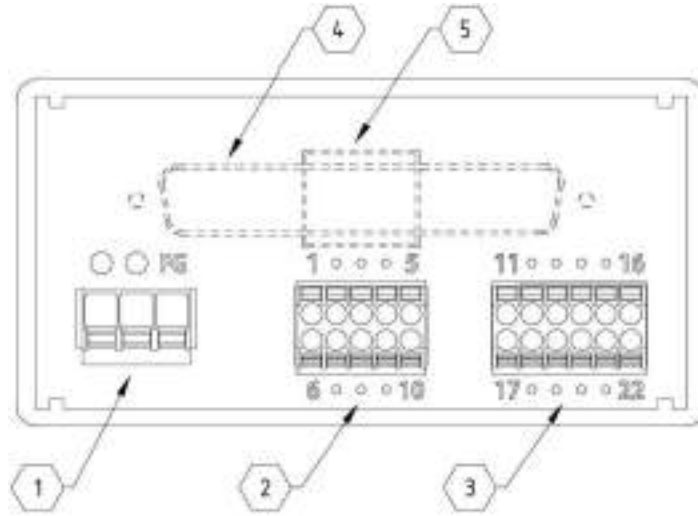

No	Name	Descriptions
1	AC-L, AC-N	Power line terminals
	FG	Power earth terminals
2	TXD, RXD	RS-232 bus terminals
	GND	RS-232 / RS-485 ground terminal
	485-A, 485-B	RS-485 bus terminals
	EX+, EX-	Sensor voltage supply terminals
	SIG+, SIG-	Sensor signal output terminals
	COM	Sensor common terminal
3	IN1~4	External input signal terminals
	COM	External input common terminal
	OUT1~4	External output signal terminals
	COM	External output common terminals
	AOUT	DAC output terminal
	ACOM	DAC common terminal

4. Installation

Panel Mounting Instructions

1. **Panel Thickness:** Use a steel panel 2-5 mm thick.
2. **Cutout Dimensions:** Prepare a cutout measuring 92.5 × 44.5 mm in the panel.
3. **Bracket Removal:** Detach the side bracket from the main unit before installation.
4. **Mounting:** Insert the indicator from the front of the panel (through the cutout).
5. **Securing:** Reattach the side bracket from the inside of the panel to lock the unit in place.

◆ Dimensions (unit: mm)

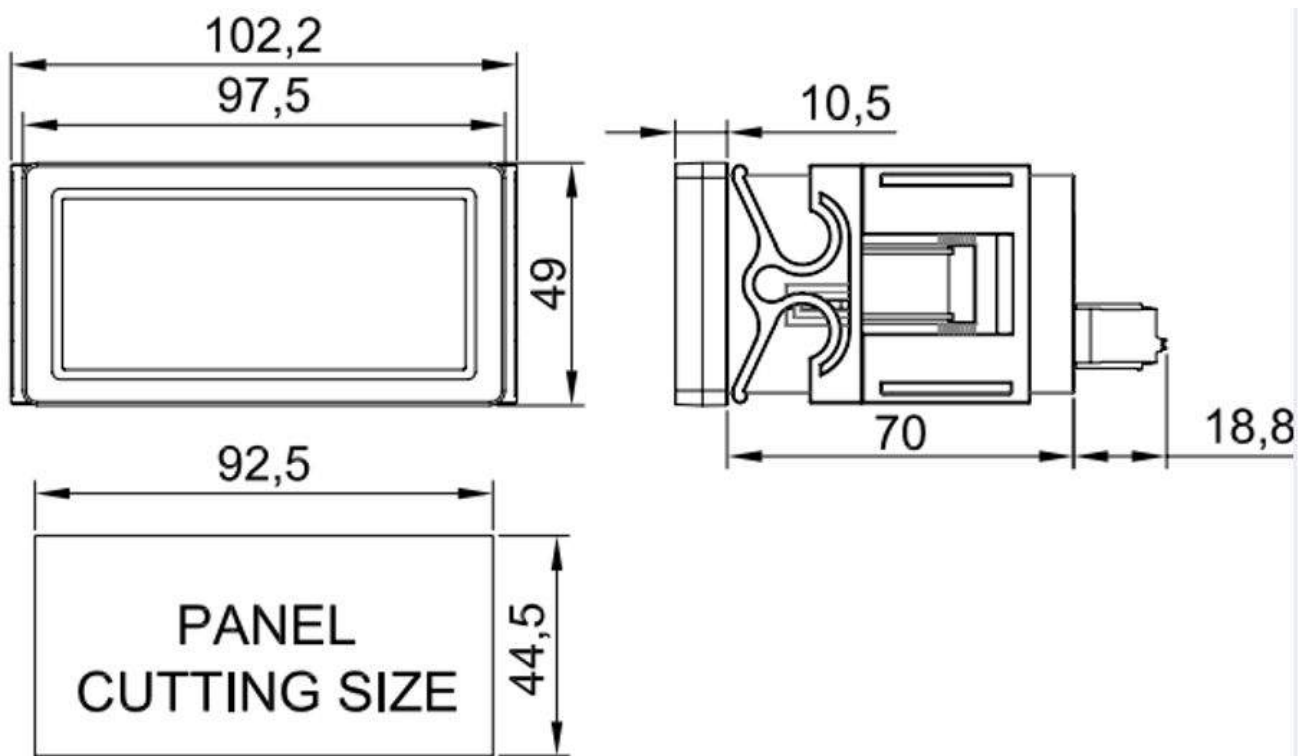

4.1 Wiring Instructions

To connect a wire, press the terminal block button, insert the wire into the hole, and release the button to secure it. After wiring, lightly pull on the wire to ensure a firm connection.

Always disconnect power before wiring and verify the location and function of each terminal to prevent errors and safety hazards.

The terminal block supports wires with a conductor diameter of 0.2 - 1.5 mm² (AWG 24 - 16). A 10 mm stripped length is recommended. For stranded wires, either solder the ends or use an I-terminal (CE005010, Φ 1.3 mm) for a reliable connection.

4.2 Power Connection

terminal	Description
○	18-36 VDC (Polarity is irrelevant)
○	
FG	GND



Ensure the equipment is properly grounded. Failure to do so may lead to issues such as vibration, fire, or malfunction.

4.3 Load Cell Connection

terminal	Load cell connection
6	EX+
7	EX-
8	SIG+
9	SIG-
10	COM

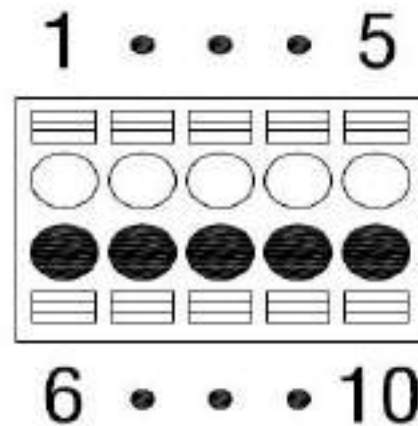

Sensor wire colors differ by manufacturer and model, so always refer to the specifications of the specific sensor being used.

This device supports up to **eight 350-ohm load cells** for connection.

5. Configurations

5.1 Supervisor Mode

Touch or press and hold the measurement value display on the initial screen to change the screen color and move to the setting menu.

i If [User Interface]-[Touch Key]-[Menu] is not 0 seconds [OFF], you can move to the settings menu by pressing and holding it for the set time.

i

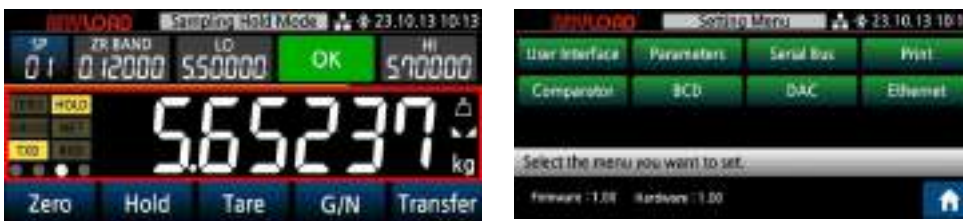

Press the [**h**] key for 1 second to go to the [Admin Password] menu. If you enter the correct

values will be displayed as blanks if the product has not been calibrated. Entering the password in the menu grants access to Supervisor Mode.

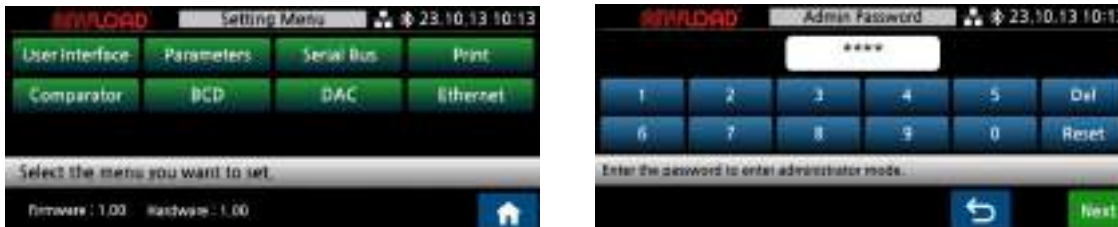

Default password: 0000, Master password: 0814

5.2 Physical Load Calibration

This mode allows calibration using an actual load, including **weight, pressure, or displacement**.

5.2.1) Direction



Select the sensor's motion direction based on the application. Choosing Bidirection enables measurement in both forward and reverse directions. For torque sensors, Bidirection must be selected.

5.2.2) Calibration point



Software correction can improve the linearity of underperforming sensors. If a single-point calibration is insufficient, select between **1 to 10 points** for adjustment.

5.2.3) Maximum capacity



Set the maximum load capacity, up to a limit of 999,999. Ensure the value accounts for the number of decimal places.

For example, if the maximum capacity is 1,000 and the display uses one decimal place (0.0), enter 10,000 to maintain accuracy.

5.2.4) Minimum division



Select a minimum division.

5.2.5) Zero calibration

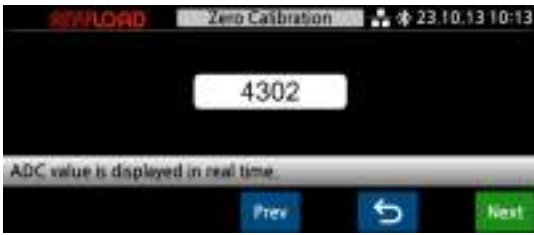

Initiate zero calibration to establish a baseline measurement. The ADC value is displayed in real time. Once the zero value stabilizes, press [Next] to proceed.

5.2.6) Span calibration



Set the test weight value and perform span calibration. If using 1-point calibration, ensure the applied load is at least 10% of the maximum capacity to improve linearity.

For multi-point calibration (e.g., 5 points):

- Each calibration step requires entering the cumulative load value for that point.
- The actual load can be applied before or after entering the value, but do not change the load when pressing [Next].
- Complete the sequence for all selected calibration points.

5.2.7) Decimal point



Select the decimal point position.

5.2.8) Verification



After completing span calibration, the load value is displayed in real time. Verify the accuracy of the calibration before proceeding.

- Press [Save] to finalize and store the calibration.
- Press [Retry] to return to Zero Calibration and perform recalibration if needed.

5.2.9) Calibration complete

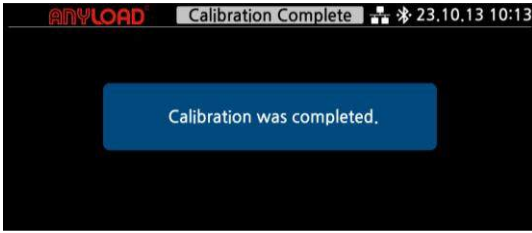

Once calibration is complete, a confirmation screen is briefly displayed before automatically returning to the main screen.

After calibration is completed, the system briefly displays a confirmation screen before returning to the main screen.

Calibration data is automatically saved in the first backup slot under Administrator Mode > Maintenance > Backup & Restore. It is recommended to manually save a backup in the third slot as an extra precaution.

If weight data issues arise, the calibration settings can be restored at any time.

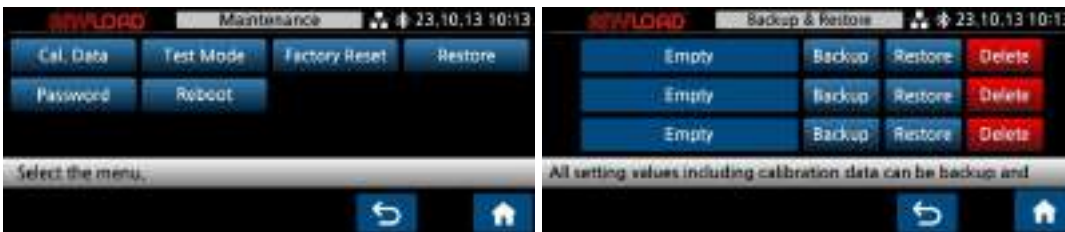

5.3 Digital Calibration

This mode allows calibration by manually entering the sensor output value in mV/V.

5.3.1) Direction

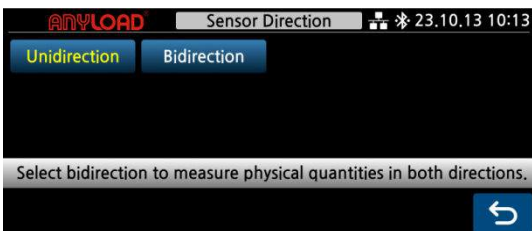

Select the sensor's direction of motion. Choosing Bidirectional enables measurement in both forward and reverse directions. For torque sensors, Bidirectional must be selected.

5.3.2) Maximum capacity



Enter the maximum load capacity, up to a limit of 999,999. Ensure the value accounts for the number of decimal places.

For example, if the maximum capacity is 1000 and the display uses one decimal place (0.0), enter 10000 to maintain accuracy.

5.3.3) Minimum division



Select a minimum division.

5.3.4) Rated capacity



Enter the rated capacity (R.C.) of the sensor as specified in the sensor report.

If multiple sensors are connected in parallel, enter the total capacity of all sensors.

For example, if using four sensors with a capacity of 1000 kg each, enter 4000.

5.3.5) Rated output

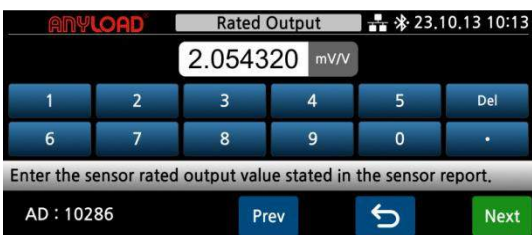

Enter the rated output of the sensor stated in the sensor report (R.O.: Rated Output). For reference, for load cells made of aluminum, the output value of the report may be different from

the actual output value, so be sure to measure

and input the actual output value with a high precision

DVM. When using two or more sensors

connected in parallel, the average output value of the sensor output must be entered.

Ex) When using 4 sensors, if the output value is 2.0103 / 1.9992 / 2.0013 / 1.9953,

respectively, input the total output value $8.005 / 4 = 2.0015$.

5.3.6) Decimal point

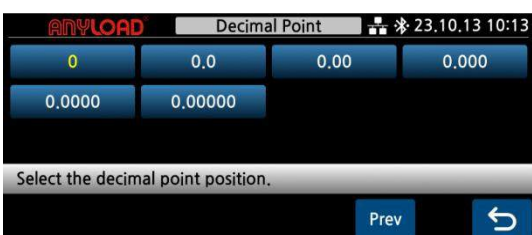

Select the decimal point desired

5.3.7) Verification



The load value is displayed in real time. Verify that the calibration has been performed correctly.

Press [Next] to complete the calibration.

Press [Retry] to return to the Rated Capacity step and perform recalibration if needed

5.3.8) Calibration complete

5.4 Gravity Compensation

This function enables calibration at one location and adjustment to match the gravitational acceleration at another location where the device will be used. Use this feature only when necessary.



Enter the gravitational acceleration of the calibration location in the Calibration field and the gravity acceleration of the actual usage location in the User Spot field.

If the gravity acceleration at the usage location is unknown, do not accept the saved default or use this function.

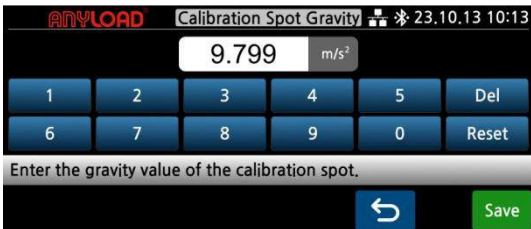

Calibration Spot Gravity Enter the gravitational acceleration of the calibration site. The domestic acceleration of gravity is 9.797~9.800m/s².

If you do not know the value, use the default value of 9.799.

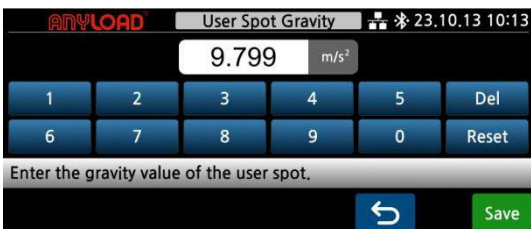

User Spot Gravity Refer to the acceleration of gravity table below and enter the acceleration of gravity at your location.

◆ Gravity acceleration for each city (Unit: m/s²)

5.5 Modifying Calibration



5.5.1) Zero calibration modification

The ADC value is displayed in real time. When the zero value stabilizes, press [Save] to confirm.

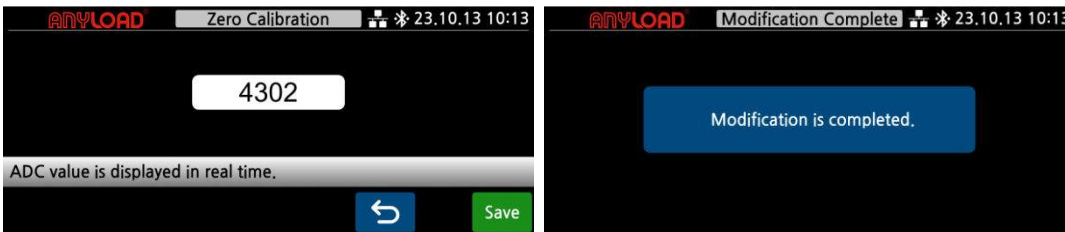

5.5.2) Resolution modification

The resolution can be adjusted by a factor of 10, either increasing or decreasing it. Select 1 to restore the original resolution.



0.1x: Removes the last digit from the displayed value.

Example: If the current value is 1998, it will be displayed as 199.

1x: Restores the original resolution after changing to 0.1x or 10x.

10x: Adds one more decimal place for finer precision.

Example: If the current value is 1998, it will be displayed as a range between 1997.5 and 1998.4.

5.5.3) Span constant modification



SPAN Constant Adjustment

Always record the current SPAN constant before making changes.

When to Adjust

If the displayed weight differs from the actual load, adjust the SPAN to correct the reading.

Formula

$$\text{New SPAN} = \left(\frac{\text{Target Value}}{\text{Current Display}} \right) \times \text{Current SPAN}$$

- **Target Value:** Actual load you want shown
- **Current Display:** What is currently shown
- **Current SPAN:** The existing SPAN constant

Example Calculation

$$\begin{aligned} \text{Target Value} &= 1000.0 \\ \text{Current Display} &= 998.0 \\ \text{Current SPAN} &= 0.9876541 \\ \text{New SPAN} &= \left(\frac{1000}{998} \right) \times 0.9876541 = 0.99763 \end{aligned}$$

Next Steps

1. Enter the new SPAN constant.
2. If the display is now correct, press **[Save]**.
3. If not, repeat the formula using the updated display and SPAN.

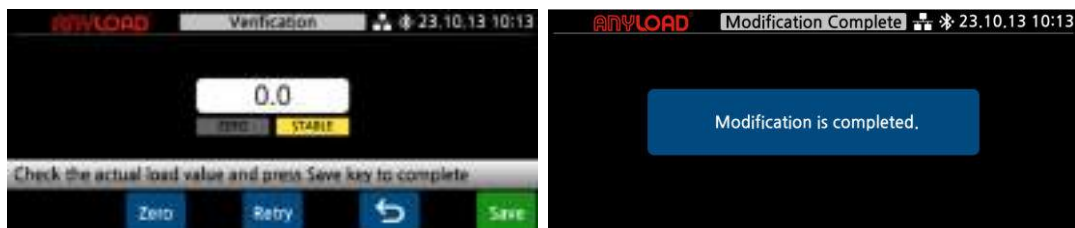

5.5.4) Sensor direction modification



This function allows changing the sensor’s measurement direction after calibration.

If a sensor is calibrated in unidirectional mode but installed with the jig in the opposite direction, the zero point may shift to a negative value, making the sensor unrecognizable. To correct this, switch the sensor to bidirectional mode, which adjusts the zero level and ensures proper detection.

This setting must be adjusted in a no-load condition, with the jig fully installed but no weight applied. After selecting the direction, wait until the sensor stabilizes, then press [Save] to confirm.

5.6 Maintenance

This mode is used for product maintenance. Select the appropriate menu option to perform maintenance tasks.



5.6.1 Calibration data

Calibration data is displayed.



5.6.2 Test mode

This mode tests the hardware of the indicator and various output functions.



5.6.3 Load sensor test



The analog-to-digital conversion (ADC) values are displayed in real time, enabling sensor performance monitoring.

5.6.4 Serial bus test



Pressing the text box transfers the displayed contents to the serial port.

5.6.5 External I/O test



When an input is detected, the lamp turns on. Activating the output switch turns on the corresponding output signal.

5.6.6 DAC test



Check the output value of the selected DAC mode.

5.6.7 Factory reset

This function resets all settings changed in setting mode to their default factory values. Calibration data, backup data, and set-point data remain unchanged.

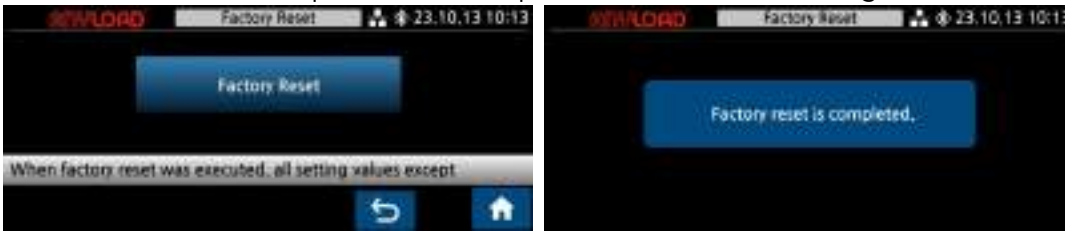

5.6.8 Backup & Restore



The calibration data is automatically backed up in the first area. To save all information, including calibration data and setting values, create a backup in an available field.

5.6.9 Change Password



Change the password required to enter the administrator mode menu.

5.6.10 Reboot



Prompts the user to confirm a system reboot. Select **YES** to proceed or **NO** to cancel.

5.6.11 Device Information



Displays the status of hardware features and communication interfaces. Use this screen to verify which modules (e.g., RS485, Wi-Fi) are enabled for the device.

5.7 Weight Compensation



This function adjusts the weight value. When the weight compensation function is enabled, the weight compensation lamp on the center right lights up.



Enter the indicator display value on the left and the weight correction value (target value) on the right.

Example: If the display value is **0.9852** and the target value is **1.0000**, the correction constant is set to **1.0150**.

5.8 Settings Mode

Adjust the operating environment as needed to ensure optimal performance.

Turn on the power and press the measurement value display on the initial screen to access the settings menu.



5.8.1 User Interface



Provides access to customizable display and key settings, including language, brightness, beeper, function keys (F1–F5), unit selection, and touch key behavior.

Use this menu to configure how the device looks and responds to user input.

5.8.2 Language



Select the language displayed on the screen.

5.8.3 Brightness



Use the left and right arrows to adjust the TFT backlight brightness.

Alternatively, press and drag the circular control to set the desired brightness level.

5.8.4 Beep

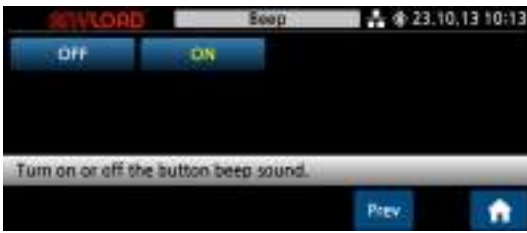

Select whether to on and off a key switch operation sound.

5.8.5 Date & time



Set the time displayed at the top of the screen. Due to potential time errors caused by operating temperature and environmental conditions, it is recommended to reset the time once a month.

5.8.6 F1 ~ F5 key function



The method for selecting functions for the F1 to F5 keys is the same.

5.8.7 Key restriction



Set the operation limit for the zero key and F1 to F5 keys. When enabled, they function only when the measured value is stable.

5.8.8 Unit



Select the units to be displayed. **Changing the unit does not automatically convert the measured value.**

5.8.9 Touch key



screen touch errors.

Ex) When setting for 2 seconds, the key must be pressed for more than 2 seconds to operate.



Set the operating time of the touch key to prevent.

5.9 Parameters



Allows fine-tuning of system behavior, including filtering, conversion rate, zero tracking, stability thresholds, and peak/hold functions.

Recommended for advanced setup or calibration adjustments.

5.9.1 Conversion rate



Select the sensor conversion speed based on the measurement requirements. Use 10 Hz or 50 Hz for general measurements and 1000 Hz or 5000 Hz for high-speed measurements.

High-speed settings provide faster response but may be less stable. For applications such as drop experiments, instantaneous values, and hold functions, higher speeds offer more accurate real-time data.

5.9.2 Low pass filter



Select the low-pass filter cutoff frequency based on the application. A higher value allows for faster response, while a lower value is recommended in environments with significant vibration to improve stability.

5.9.3 Moving average filter

Select the number of samples for the moving average filter.

The lower the number, the faster it is expressed.

In places with a lot of vibration, increase the number.

The meaning of 100 means that 100 data are averaged and displayed.



[Conversion rate 10, 50 Hz]



[Conversion rate 150 Hz]



[Conversion rate 1000 Hz]



[Conversion rate 2000 Hz]



[Conversion rate 5000 Hz]

5.9.4 Zero Motion range

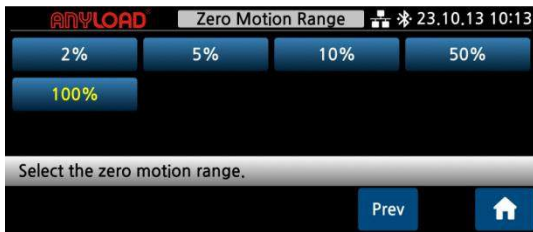

Specify the operating range for the zero button and external zero input. Set the range as a percentage of the maximum weight to define the allowable zeroing limit.

5.9.5 Zero tracking time

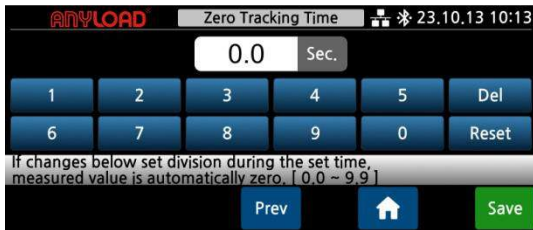

This function automatically resets the zero point when it drifts due to fine dust accumulation or when the sensor does not return to zero after the load is fully removed.

5.9.6 Zero tracking division



Set the zero time and zero width to appropriate values. For example, if the zero time is set to 0.5 and the zero width is 1.0, the system will automatically reset to zero if the measured value changes within 1.0 division for 0.5 seconds.

5.9.7 Stable detection time



Set the stable time and stable division to determine when the stability lamp activates. The lamp will light up when the measured value remains within the specified division range for the set time.

5.9.8 Stable detection division

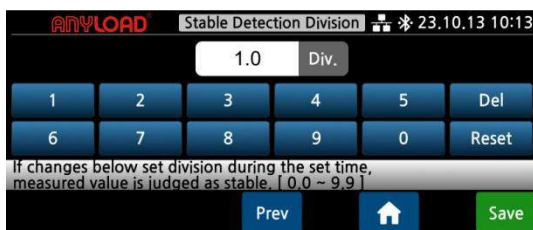

The stability lamp turns on when the measured value remains within the stable width during the settling time.

5.9.9 Weight backup



When OFF is selected, the measured value is reset to 0 each time the power is turned on.

When ON is selected, the current sensor measurement value is displayed at startup.

5.9.10 Hold Function

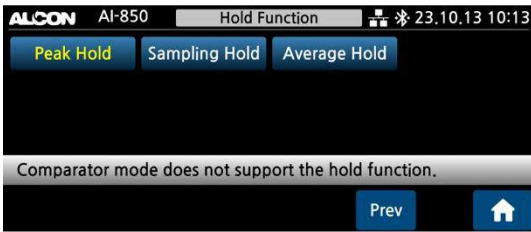

Peak hold: Captures and holds the highest measured value.

Sample hold: Holds the current value when the hold button is pressed or when an external hold signal is activated.

Average hold: Holds the average of measured values over a set period.

5.10 Serial Bus



Select the serial bus type and device id.

5.10.1 Baud rate



Select the communication speed.

5.10.2 Data bit

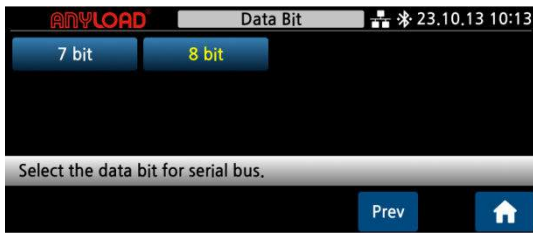

Select the data bit for serial bus.

5.10.3 Stop bit



Select the stop bit for serial bus.

5.10.4 Parity bit



Select elect the parity bit for serial bus.

5.10.5 Serial mode



Selecting Communication Mode:

Select the data transmission mode based on the required operation:

- Manual: Sends data once when the front transmission button is pressed.
- Stable: Sends data once when the measurement value stabilizes.
- Decision: Sends data upon judgment in comparator mode.
- Stream: Continuously transmits data in real time at a rate of one transfer per 10 milliseconds.
- Command: Sends data only when a command request is received.
- Interval: Sends data at predefined time intervals.
- ModBus: Refer to section 10. ModBus-RTU for details.
- Command Reception: Refer to section 8. Command Reception Mode for details.

5.10.6 Serial format

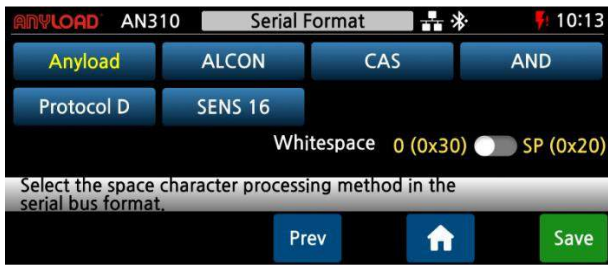

Anyload: 19 bytes

CASKOREA: 22 bytes

CAS: 22 bytes

AND: 18 bytes

Protocol D: Non-contact torque sensor 21 bytes

SENS16: 16 bytes

Select the space character processing method among communication formats. It is recommended to select 0x20 for PC and 0x30 for PLC.

i Refer to 『8. Serial Interface』 for wiring method and serial format.

5.10.7 ID

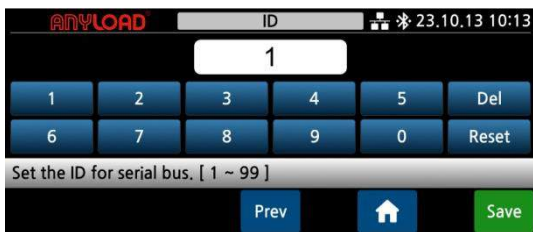

The device ID is assigned to distinguish multiple devices when connected via serial communication. For torque sensors, the ID must be a single digit.

WARNING: Perform this procedure only if resetting the tare of the weighed structure is not possible, such as when the system contains product that cannot be unloaded.

Set the estimated zero value within the range of **0 to 999999** (default: **0**).

5.11 Print & Save

5.11.1 Print port

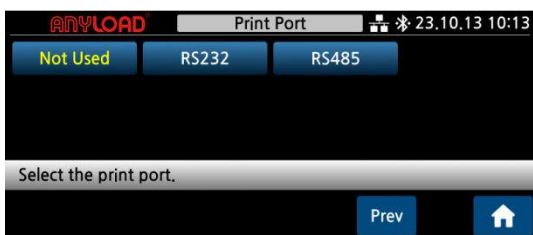

Select the print port.

5.11.2 Mode



Manual: Print when the PRINT button is pressed.

Stable: Print when the value is stable.

Decision: Print when decision signal is turn on in comparator mode.

Interval: Print every set time interval.

5.11.3 Print item



DATE	2023-10-13 10:13
S/N	00001
GROSS	2.57614kg
TARE	1.00000kg
NET	1.57614kg

You can enable or disable print items.

5.11.4 Line feed

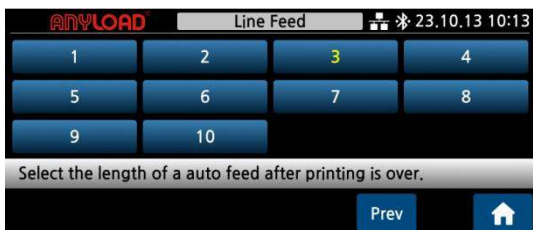

Select the interval at which paper is ejected after printing.

5.12 Comparator



Select the comparator mode

Comparator mode vs. external output (RY1~4)

Mode	RY1	RY2	RY3	RY4
Sampling hold	Zero band	LO	OK	HI
Auto / Manual peak hold				
Checker				
Limit checker				
Limit	Zero band	LO	FINAL	HI
4 Charge	LL	LO	HI	HH
4 Charge (RY1 value: 0)	Zero band	LO	HI	HH

WARNING: Identify and resolve any mechanical issues before repeating the procedure.

- If the theoretical full scale matches the recalculated full scale during real calibration, the system is operating with theoretical calibration. If the values differ, the system is using real calibration based on sample weights.
 - If the applied correction changes the previous full scale by more than 20%, all parameters containing settable weight values will be reset to default.
- ◆ How to set the set-point code and value

If you press the set-point field in the red area below, the input window is displayed.



5.13.1 Set Point



Enter the desired set point value (0-99) for the selected mode.

5.13.2 Sampling hold, auto peak hold, Manual peak hold, Limit, Checker, Limit checker



Set the lower (LO) and upper (HI) thresholds for the selected set point mode.

5.13.3 Charge



Set the low-low (LL), low (LO), high (HI), and high-high (HH) thresholds for the selected set point mode.

1) **Sampling hold mode - Automatic hold decision**

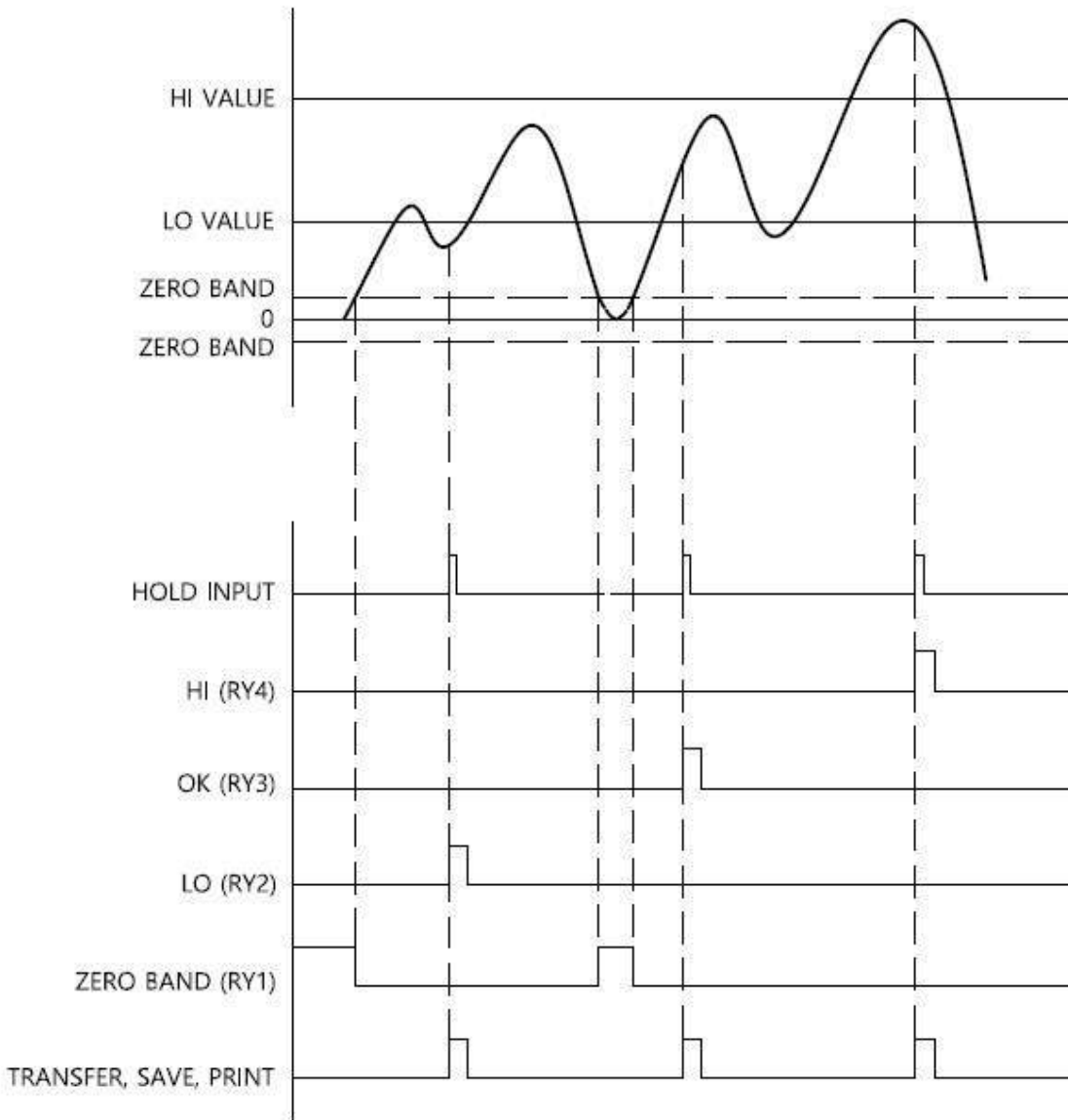

- ◆ Select Sampling Hold in the comparator mode and set the hold decision method to Automatic.
 - ◆ LO/OK/HI output activates after the specified Delay Time and deactivates after the Output Time.
- ◆ If Output Time is set to 0, the output remains active continuously and can only be canceled using a reset signal.
- ◆ Avoid applying the hold input signal again within the Output Time to prevent unintended operation.
- ◆ The function does not operate within the zero band.
- ◆ Decision values can be transferred, saved, and printed.

2) Sampling hold mode - Manual hold decision method

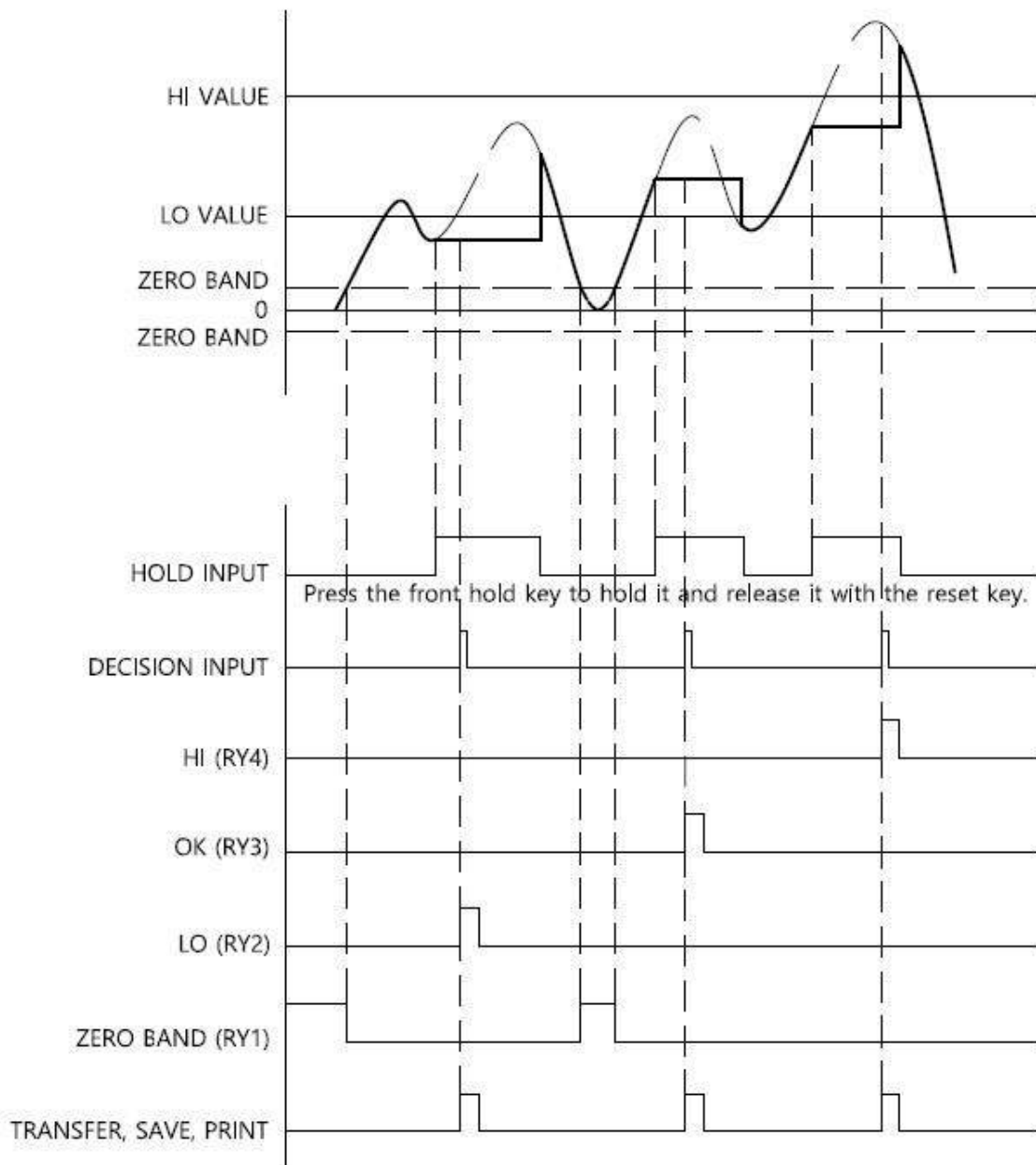

Select Sampling Hold in the comparator mode and set the hold decision method to Manual.

◆ LO/OK/HI output activates after the specified Delay Time and deactivates after the Output Time.

◆ IOutput Time is set to 0, the output remains active continuously and can only be canceled using a reset signal.

- ◆ Avoid applying the hold input signal again within the Output Time to prevent unintended operation.
- ◆ The function does not operate within the zero band. Decision values can be transferred, saved, and printed.

3) Auto Peak Hold Mode

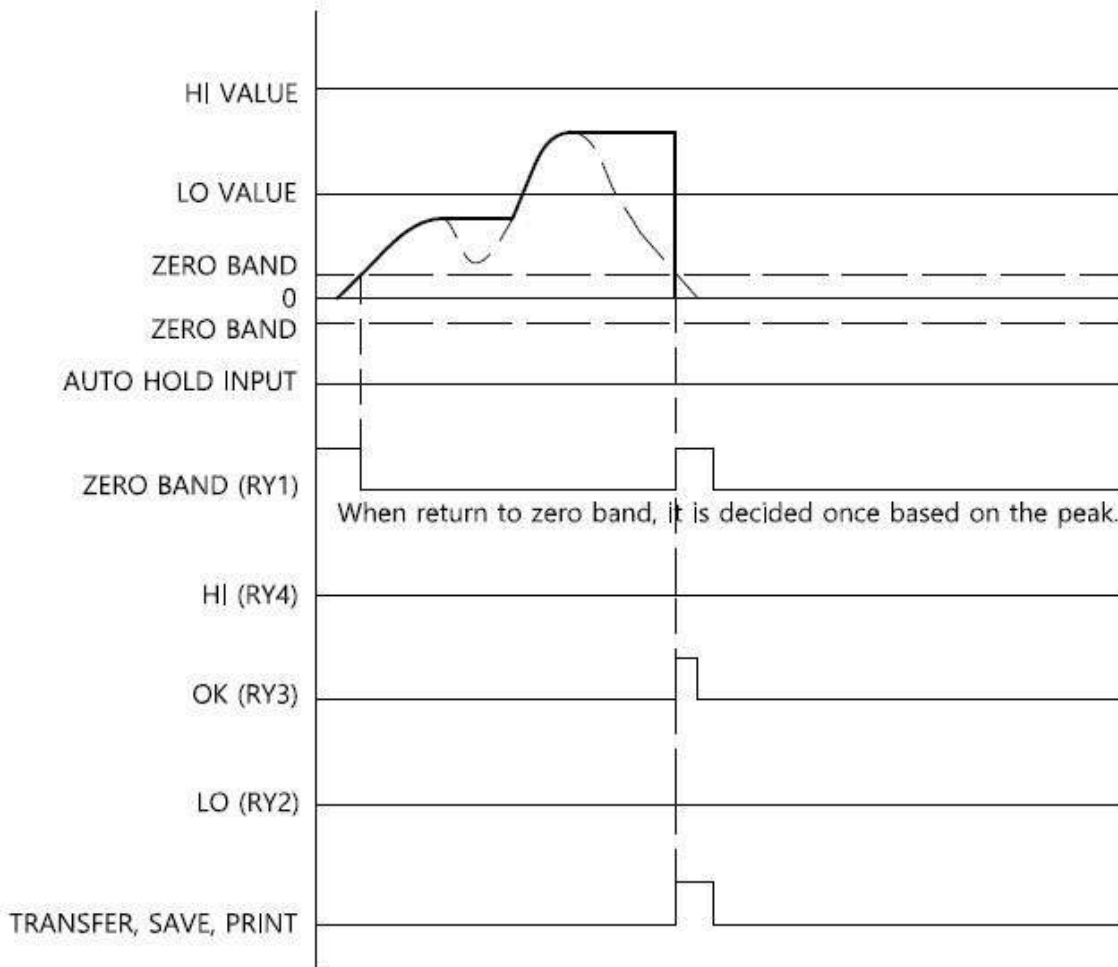

- ◆ Select the [A. Peak Hold] in the comparator mode.
- ◆ LO/OK/HI signals are output in the zero band.
- ◆ LO/OK/HI output activates after the specified Delay Time and deactivates after the Output Time.
- ◆ If Output Time is set to 0, the output remains active continuously and can only be canceled using a reset signal.
- ◆ Decision values can be transferred, saved, and printed.

4) Manual peak hold mode

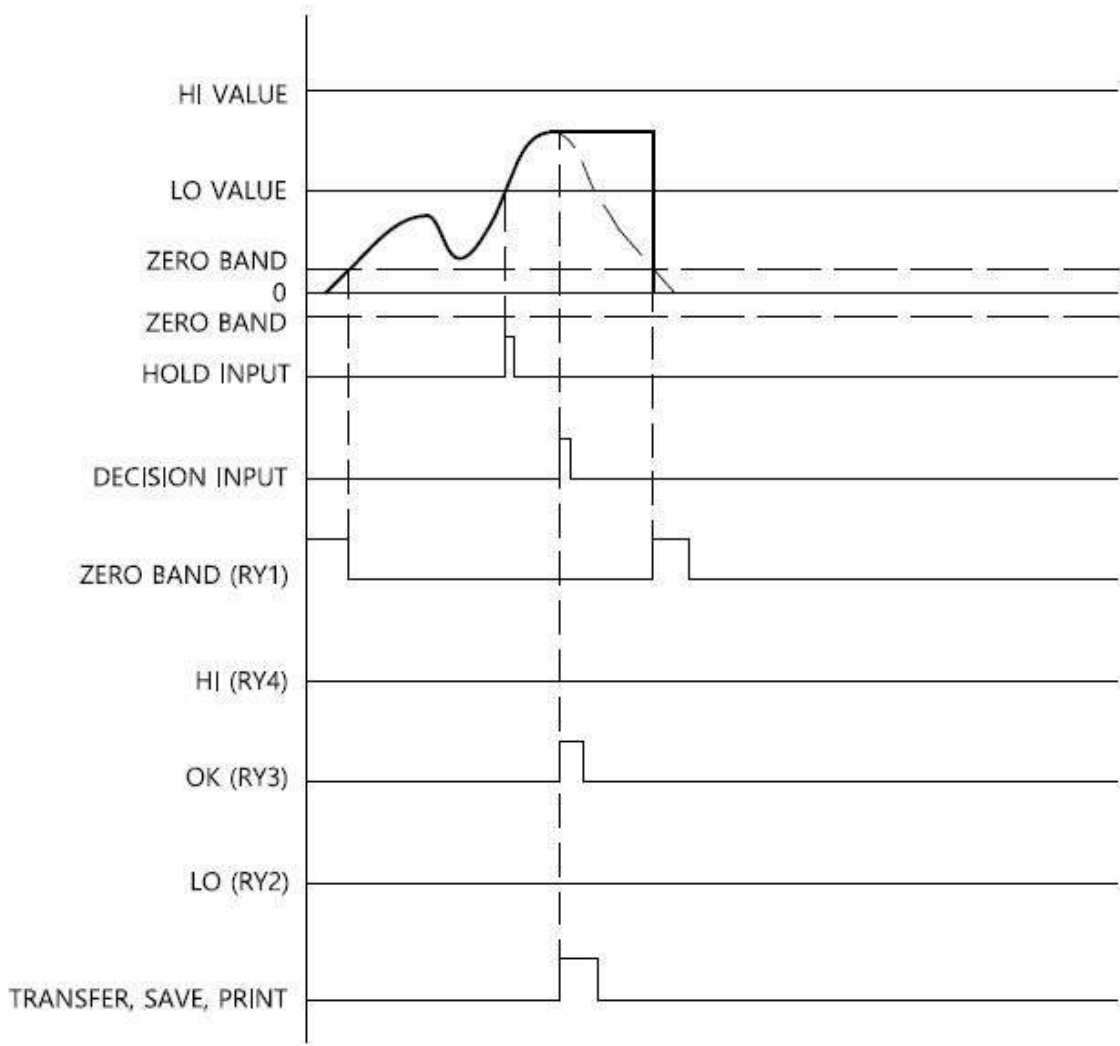

Select M. Peak Hold in the comparator mode.

- ◆ If the hold decision method is set to Manual, LO/OK/HI signals are output when the hold input is received, as shown in the reference graph. If set to Automatic, signals are output within the zero band.
- ◆ LO/OK/HI output activates after the specified Delay Time and deactivates after the Output Time.
- ◆ If Output Time is set to 0, the output remains active continuously and can only be canceled using a reset signal.
- ◆ Decision values can be transferred, saved, and printed.

5) Limit Mode

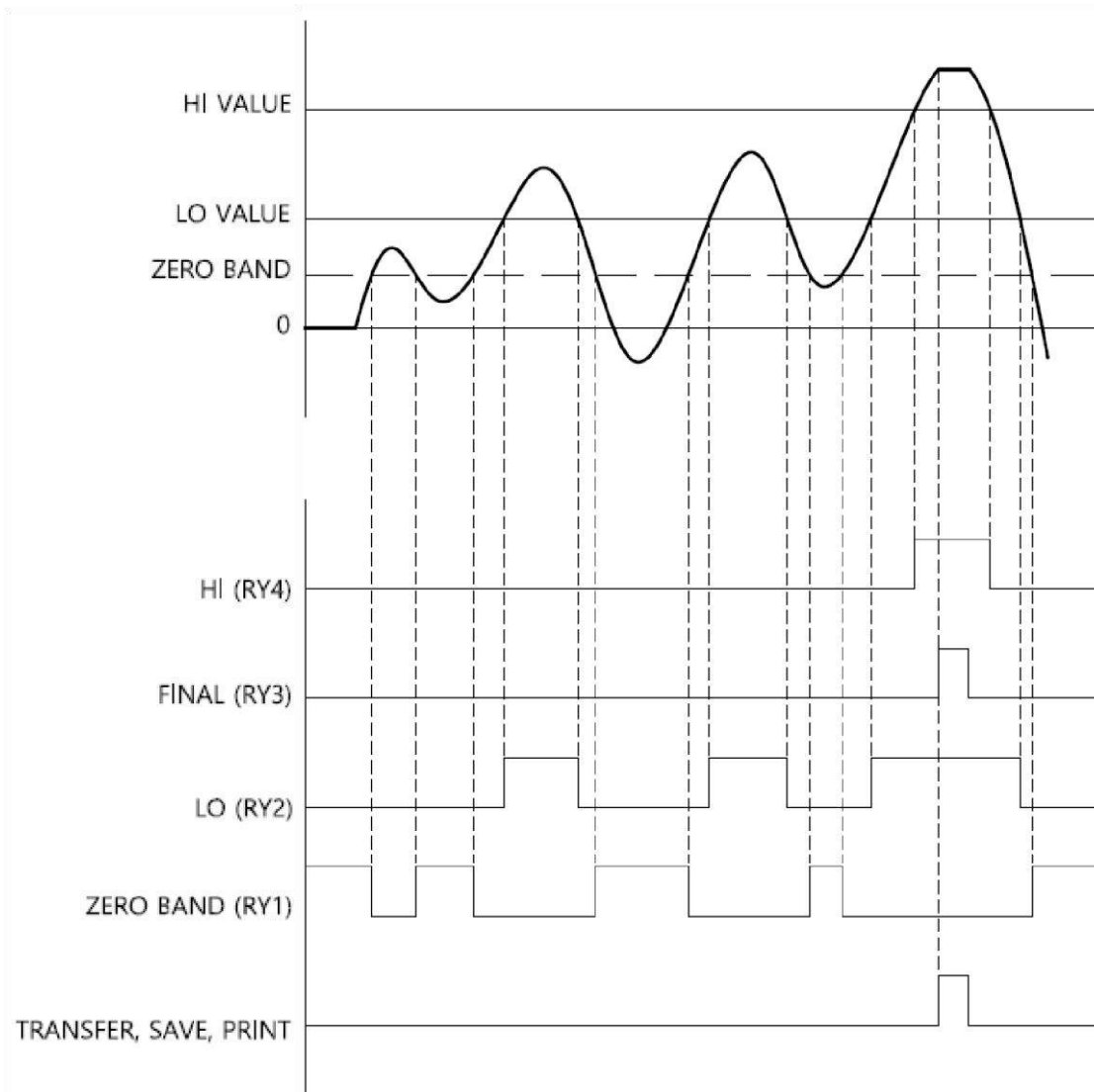

- ◆ Select Limit in the comparator mode.
- ◆ LO/FINAL/HI output is directly linked to the measured value, unaffected by Delay Time and Output Time.
- ◆ The FINAL signal (RY3) is triggered when the value stabilizes above the HI value.
- ◆ If free fall is set, the HI signal (RY4) is activated from HI value - free fall value.
- ◆ The function does not operate within the zero band. Decision values can be transferred, saved, and printed

6) Checker Mode

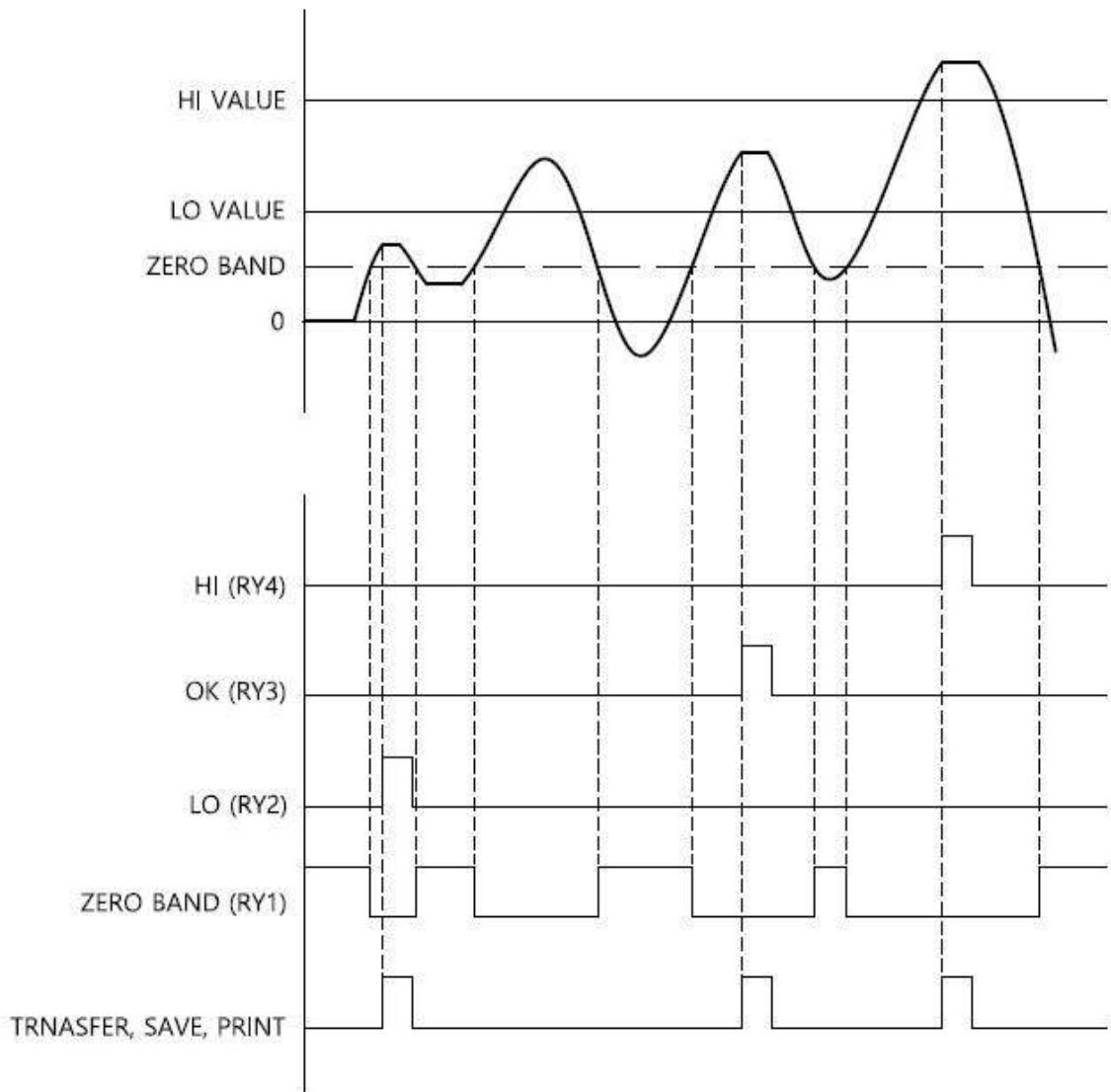

- ◆ Select Checker in the comparator mode.
- ◆ LO/OK/HI output activates after the specified Delay Time and deactivates after the Output Time.
- ◆ If Output Time is set to 0, the output remains active continuously and can only be canceled using a reset signal.
- ◆ LO/OK/HI signals are triggered when the measured value stabilizes above the zero band.
- ◆ The function does not operate within the zero band. Decision values can be transferred, saved, and printed.

7) Limit Checker Mode

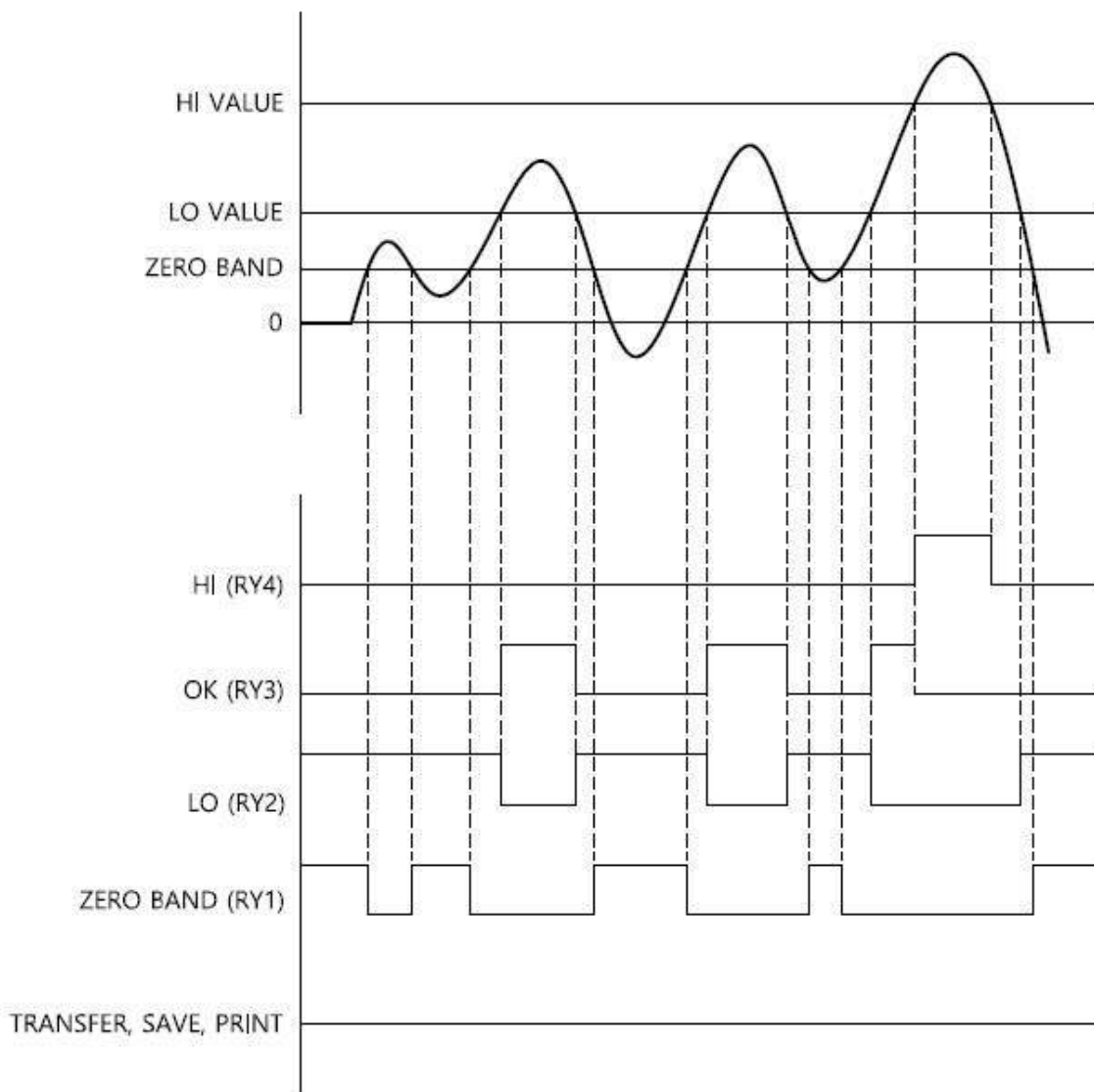

- ◆ Select the [Limit checker] in the comparator mode.
- ◆ LO/OK/HI is linked output to the measured value regardless of [Delay Time] and [Output Time].
- ◆ The function does not operate within the zero band.
- ◆ Decision values can be transferred, saved, and printed.

8) 4 Charge Mode

SET VALUE \ OUTPUT	0 kg	LL 25 kg	LO 50 kg	HI 75 kg	HH 100 kg
LL (RY1)	Low	High	High	High	High
LO (RY2)	Low	Low	High	High	High
HI (RY3)	Low	Low	Low	High	High
HH (RY4)	Low	Low	Low	Low	High
TRANSFER, SAVE and PRINT	It depends on the operating conditions of each function.				

Select the [4 Charge] in the comparator mode.

- ◆ If the LL value is set to 0, the LL output operates as the zero band output.
- ◆ LL/OK/HI/HH output is directly linked to the measured value, unaffected by Delay Time and Output Time.
- ◆ If free fall is set, the HH signal (RY4) is activated from HH value - free fall value.
- ◆ The function does not operate within the zero band. Decision values can be transferred, saved, and printed.

5.14 Comparator Setting

5.14.1 Zero band



In comparator mode, values below the zero band are fixed at 0, with only the zero signal output.

5.14.2 Free fall



In Limit Mode, HI output is triggered at HI value - free fall value.

In 4 Charge Mode, HH output is triggered at HH value - free fall value.

5.14.3 Form A, B

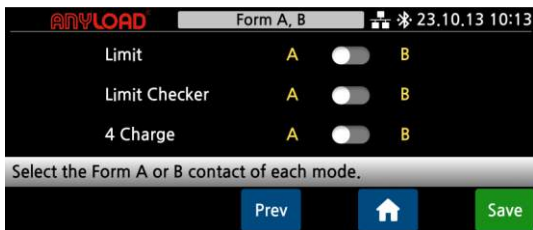

A/B contact of comparator mode output can be selected.

5.14.4 Delay time



Set the delay time for external output. The output activates after the specified input time for each item.

This setting is not applicable in Limit Mode and Limit Checker Mode.

5.14.5 Output time

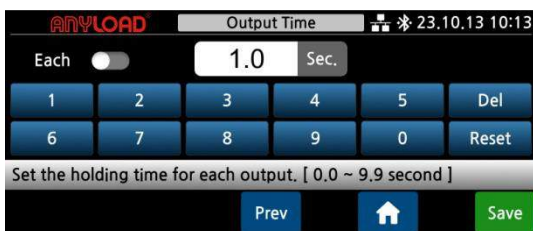

Set the output time for external output. The output turns OFF after the specified duration.

This setting is not applicable in Limit Mode and Limit Checker Mode.

5.14.6 IN1~IN4

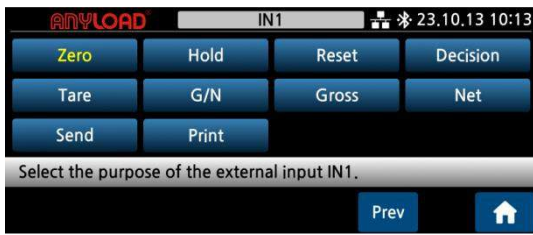

Set the functions of external inputs IN1 to IN4.

[Transfer] sends data to an external communication device (printer, PC, etc.). [Save] saves data in SD Memory Card.

5.15 Ethernet



Access Ethernet settings to configure DHCP, Static IP, connection method, server settings, and data format.

5.15.1 DHCP



DHCP is a protocol where network devices are automatically assigned IP addresses. When DHCP is ON, an IP address is automatically obtained from the network.

5.15.2 Static IP



Manual IP setting is a method where the user directly enters the IP address, subnet mask, and gateway to connect to the network.

Operates when DHCP is OFF.

5.15.3 Method



Set the Ethernet communication method.

5.15.4 Server IP



If the Ethernet communication method is server, set the server IP address.

5.15.5 Port



Set the port number to be used for Ethernet communication.

5.15.6 Mode



Select communication mode.

Manual: Transfers data once when the TX button is pressed.

Stable: Transfers data once when the measured value is stable.

Decision: Transfers data when the

decision signal activates in comparator mode.

Stream: Continuously transfers the measured value in real time.

Command: Transfers data on request from external equipment.

Interval: Transfers data at a set time interval.

ModBus: Refer to Section 11: ModBus-RTU for details.

High Speed: Baud rate is fixed at 256K, with a conversion speed of 350Hz. User adjustment of the baud rate is not allowed.

Note: When using a **USB serial converter**, occasional delays of approximately **100ms** may occur due to buffer usage.

5.15.7 Ethernet Format



Anyload: 19 bytes

CASKOREA: 22 bytes

CAS: 22 bytes

AND: 18 bytes

Protocol D: Non-contact torque sensor 21 bytes

SENS16: 16 bytes

5.15.8 Info



You can check information about current Ethernet communication.

5.16 DAC Mode

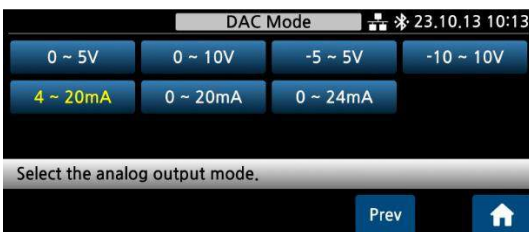

Select the desired analog signal format (e.g. voltage or current) based on your system's requirements.

5.16.1 DAC Maximum Output



Enter the weight value that will produce the maximum analog output (e.g. 10V or 20mA).

5.16.2 DAC Tuning



Use the tuning buttons while measuring the AOUT and AGND terminals to fine-tune the analog signal.

5.16.3 Analogue connection

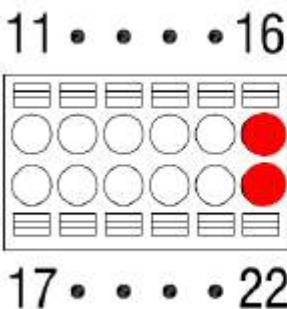

Terminal	DAC
16	Analog out
22	COM

6. Serial Interface

6.1 Serial Connection

Since the serial interface is sensitive to **electrical noise**, route it separately from power lines and other electrical wiring. Always use **shielded cables** to minimize interference.

Refer to the setting mode for serial interface method selection.

- Internal circuit is electrically isolated from the external circuit and is not affected by external noise.

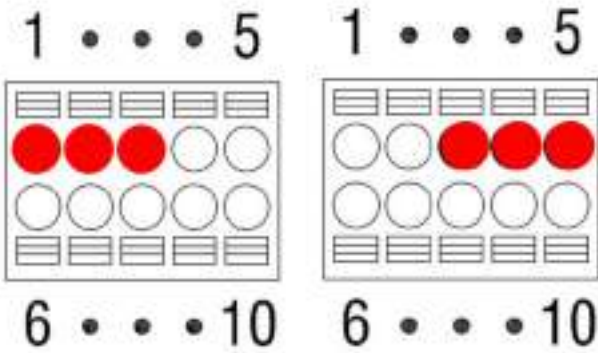

Port	RS-232
1	TXD
2	RXD
3	Serial GND

Port	RS-485
3	Serial GND
4	485-A
5	485-B

Please use a shielded twisted pair cable for the connection cable.

When communicating with RS-485, install terminating resistors on both ends of the wiring.

Typically 100Ω~120Ω is used and may vary depending on the environment.

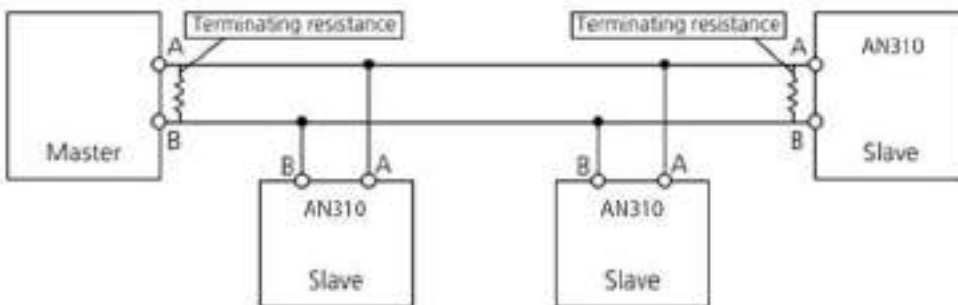

6.2 Serial Format

Anyload format (19 bytes)

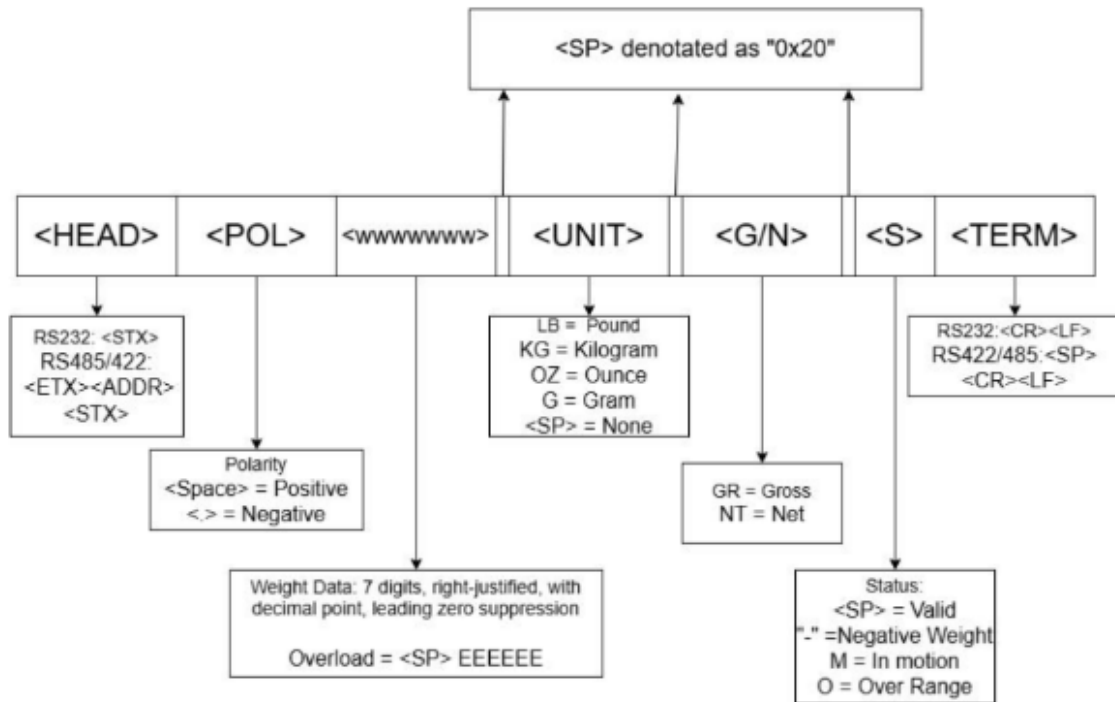

CASKOREA format (22 byte)

HEX	ASCII (XOR CRC range)													ASCII	HEX					
STX	ID		H1		H2		Measured value					Unit	CRC	ETX						
0x02	9	9	,	3	,	Null	,	+				0	.	0	,	2	9	F	F	0x03

[H1: Status header]

H1	Stable	Unstable	Overload	Hold	LO	OK	HI
Code	0	1	2	3	4	5	6

❗ In stream mode, code 4, 5, 6 are not transfer.

[Unit code]

Unit	null	g	kg	ton	lb	N	kN	Pa	kPa	MPa	Bar	mm	kgf	kgf*cm	kgf*m
1 st	0	0	0	0	0	0	0	0	0	0	1	1	1	1	1

Measured value	e.g.1) 13.5kg '+',,,,,,,',1','3',.,',5' e.g.2) 135kg '+',,,,,,,',1','3','5' e.g.3) -13.5kg '-',,,,,,,',1','3',.,',5'	
Unit	Same as the unit of measurement of the CASKOREA format above.	
End	CR LF	(0x0D)(0x0A)

◆ Protocol D (21 bytes) - When using torque sensor or 2channel sensor.

e.g., When ID is 1 and measured value is +123.45

	Start	ID		Length		Mark	Channel		Data	CheckSum		End
ASCII	STX	0	1	0	A	D	0	1	See below	6	3	ETX
HEX	0x02	0x30	0x31	0x30	0x45	0x44	0x30	0x31		0x36	0x33	0x03



Data(10 Bytes)										
	Index		Measurement Value (8 bytes)							
ASCII	0	0	+	0	1	2	3	.	4	5
HEX	0x30	0x30	0x2B	0x30	0x31	0x32	0x33	0x2E	0x34	0x35

◆ SENS16 Format (16 byte)

ID Measured value End

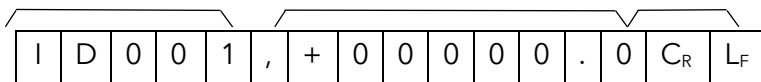

ID	ID (0x49) (0x44) + ASCII 3-byte number
Measured value	e.g.1) 13.5kg '+',,,,,,,',1','3',.,',5' e.g.2) 135kg '+',,,,,,,',1','3','5' e.g.3) -13.5kg '-',,,,,,,',1','3',.,',5'
End	CR LF (0x0D)(0x0A)

6.3 Command Mode

Command mode can be used when operating this device from an external device.

◆ Command 1

Code	Start	ID			Command	End	Example value
ASCII	STX	0	1	,	Change the number of digits	ETX	02 01, MF 03
HEX	02	30	31	2C		03	02 30 31 2C 4D 46 03

❗ If you are not using a device number, you can exclude the device number and the separator (,).

Function	Command (Values in parentheses are HEX)	Response from indicator
Read measured value	MF (4D 46)	Transfer to PC in the set format
Zero	MZ (4D 5A)	Echo response, OK(NG)
Hold	MH (4D 48)	
Reset	MR (4D 52)	
Tare	MT (4D 54)	
Gross	MG (4D 47)	
Net	MN (4D 4E)	
Print	MP (4D 50)	
Decision	MJ (4D 4A)	
G/N	MS (4D 53)	
Write set-point code	S01 (53 30 31) Write to SP1	
Write RY1~RY4	S01,1,0.2 (53 30 31 2C 31 2C 30 2E 32) Write the RY1(0.2) of SP1	
Read set-point code	RS (52 53) Request the set-point code	e.g., S02
Read RY1~RY4	R01,1 (52 30 31 2C 31) Request the RY1 of SP1	e.g., S01,1,0.2
Check comparator	RC (52 43) Request the comparator status	e.g., C0010,1000 C RY1 2 3 4, IN1 2 3 4 * RY3 ON, IN1 ON
Write Date & Time	G23,07,14,11,11 (47 32 33 2C 30 37 2C 31 34 2C 31 31 2C 31 31)	

Command 2

Code	Start	ID		Command	End	Example value
ASCII	STX	0	1	Change the number of digits	ETX	01RCWT
HEX	02	30	31		03	02 30 31 52 43 57 54 03

READ COMMAND

Function	Command	Response from indicator	
Measured value	RCWT (52 43 57 54)	ASCII	01RCWTSTNT+00027.602
		HEX	02 30 31 52 43 57 54 53 54 4E 2B 30 30 30 32 37 2E 36 30 32 03
		Response structure (22 bytes total)	STX(1) + ID(2) + Command(4) + State1(2) + State2(2) + Sign(1) + Weight(7) + Decimal Point(7) + Unit(2) + ETX(1)
		State1	O = ST, US / N = T, GS;
		Unit	same as the measurement unit configured in the CASKOREA format.
set-point code	RPNO (52 50 4E 4F)	ASCII	01RPNO01
		HEX	02 30 31 52 50 4E 4F 30 31 03
Key Tare Value	RTAR (52 54 41 52)	ASCII	01RTAR000050
		HEX	02 30 31 52 54 41 52 30 30 30 30 35 30 03
SP1 (Comparator Output)	RSP1 (52 53 50 31)	ASCII	01RSP1010000
		HEX	02 30 31 52 53 50 31 30 31 30 30 03
		Operation	Operates by comparator mode. In 4-charge mode, SP1 is Low. If HL = 0, it retrieves the value near zero. Does not operate when turned off. In absence of a mode setting, defaults to LO.
SP2 (Comparator Output)	RSP2 (52 53 50 32)	ASCII	01RSP2020000
		HEX	02 30 31 52 53 50 32 30 32 30 30 03
		Operation	Comparator mode only. In 4-charge mode, SP2 is Low. Defaults to HI if mode is not set.
SP3 (Comparator Output)	RSP3 (52 53 50 33)	ASCII	01RSP3030000
		HEX	02 30 31 52 53 50 33 30 33 30 30 03
		Operation	Comparator mode only. In 4-charge mode, SP3 is High. Does not function in other modes.
SP4 (Comparator Output)	RSP4 (52 53 50 34)	ASCII	01RSP4040000
		HEX	02 30 31 52 53 50 34 30 34 30 30 03
		Operation	Comparator mode only. In 4-charge mode, SP4 is High. It does not work in other modes.

WRITE COMMAND

Success (ACK: 06), Failure (NAK: 15)

Function	Command	Response (sent from controller)	
Zero	WZER (57 5A 45 52)	ASCII	01WZER
		HEX	02 30 31 57 5A 45 52 06 03
Hold	WHOL (57 48 4F 4C)	ASCII	01WHOL
		HEX	02 30 31 57 48 4F 4C 06 03
Hold Reset	WHRS (57 48 52 53)	ASCII	01WHRS
		HEX	02 30 31 57 48 52 53 06 03
Tare	WTAR (57 54 41 52)	ASCII	01WTAR
		HEX	02 30 31 57 54 41 52 06 03
Tare Reset (Comparator)	WTRS (57 54 52 53)	ASCII	01WTRS
		HEX	02 30 31 57 54 52 53 06 03
Set-point code	WPNO01 (57 50 4E 4F 30 31)	ASCII	01WPNO
		HEX	02 30 31 57 50 4E 4F 06 03
SP1 Write	WSP1 (57 53 50 31)	Example Data Write	WSP1000200 (57 53 50 31 30 30 30 32 30)
		ASCII	01WSP1
		HEX	02 30 31 57 53 50 31 06 03
		Operation Description	In comparator mode, SP1 is Low in 4-charge mode. If HL = 0, it retrieves a near-zero value. Does not operate when turned off. Defaults to LO in other modes.
SP2 Write	WSP2 (57 53 50 32)	Example Data Write	WSP2000400 (57 53 50 32 30 30 30 34 30 30)
		ASCII	01WSP2
		HEX	02 30 31 57 53 50 32 06 03
		Operation Description	In comparator mode, SP2 is Low in 4-charge mode. Defaults to HI in other modes. Does not operate when turned off.
SP3 Write	WSP3 (57 53 50 33)	Example Data Write	WSP3000600 (57 53 50 33 30 30 30 36 30 30)
		ASCII	01WSP3
		HEX	02 30 31 57 53 50 33 06 03
		Operation Description	In comparator mode, SP3 is High in 4-charge mode. Does not operate in other modes.
SP4 Write	WSP4 (57 53 50 34)	Example Data Write	WSP4000800 (57 53 50 34 30 30 30 38 30 30)
		ASCII	01WSP4
		HEX	02 30 31 57 53 50 34 06 03
		Operation Description	In comparator mode, SP4 is High in 4-charge mode. Does not operate in other modes.

7. External I/O Comparator

7.1 External Input

It operates when the external input terminal is shorted to the common GND terminal or energized through a photo-coupler.

- ❶ Internal circuit is electrically isolated from the external circuit, so it is not affected by External noise

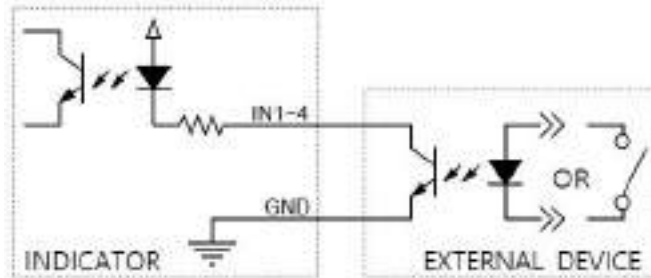
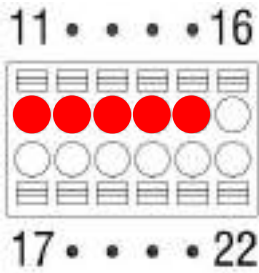

7.2 External Output

The external output is an open collector, and connect using a photo coupler or relay. The maximum load on the output terminal is AC/DC 350V, 120mA.

- ❶ Internal circuit is electrically isolated from the external circuit and is not affected by external noise.

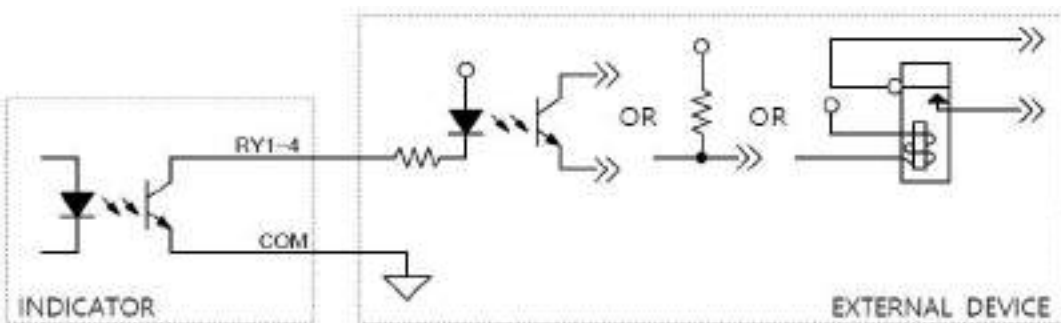
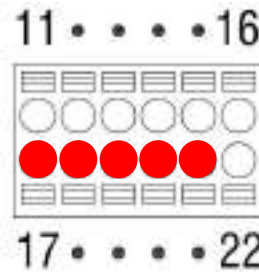

8. ModBus-RTU

It is a type of Modbus protocol for operating in RS-485 communication environment. It is a protocol that identifies each device through device ID and checks errors using CRC to communicate.

Function code 03h : Read Holding Registers

06h : Write Single Registers

Function code 10h : Write Multiple Registers

ADR. (HEX)	ADR (DEC)	LEN	R/W	Description
00h	0	2	RO	Maximum capacity
02h	2	1	RO	Minimum division
03h	3	1	RO	Decimal point
04h	4	2	RO	ADC value
06h	6	2	RO	Measured value
08h	8	1	RO	Lamp status
09h	9	1	RO	Error data
0Ah	10	20	-	Reserved
1Eh	30	1	RO	Comparator mode
1Fh	31	2	RO	External in/output
21h	33	27	-	Reserved

ADR. (HEX)	ADR (DEC)	LEN	R/W	Description
3Ch	60	2	RW	Date
3Eh	62	2	RW	Time
40h	64	1	WO	External input command
41h	65	1	RW	Set-Point code
42h	66	2	RW	RY1 value
44h	68	2	RW	RY2 value
46h	70	2	RW	RY3 value
48h	72	2	RW	RY4 value
4Ah	74	26	-	Reserved

RO: Read only, WO: Write only, RW: Read-Write

◆ Lamp status map

8bit	7bit	6bit	5bit	4bit	3bit	2bit	1bit
			Stable	Net	Gross	Hold	Zero

◆ Error data map

8bit	7bit	6bit	5bit	4bit	3bit	2bit	1bit
Overload							Sensor

◆ Comparator map

0	1	2	3	4
OFF	Sampling hold	Auto peak hold	Manual peak hold	Checker
5	6	7		
Limit checker	Limit	4 charge		

◆ External in/output

16bit	15bit	14bit	13bit	12bit	11bit	10bit	9bit
				RY4	RY3	RY2	RY1
8bit	7bit	6bit	5bit	4bit	3bit	2bit	1bit
				IN4	IN3	IN2	IN1

◆ External input command

1	2	3	4	5
Zero	Hold	Reset	Decision	Tare
6	7	8	9	10
Gross/Net	Gross	Net	Transfer	Print

e.g., 2021/10/13 14:30:15 Write, Read

Slave Address	Starting Address	Number of Register
1	3Ch	4

Request	
Field Name	Hex
Slave Address (Device ID)	01h
Function	10h
Starting Address High	00h
Starting Address Low	3Ch
Number of Register High	00h
Number of Register Low	04h
Byte Count	08h
Date High	00h
Date High	03h
Date Low	38h
Date Low	45h
Time High	00h
Time High	02h
Time Low	2Eh
Time Low	A7h
CRC Code High	XX
CRC Code Low	XX

Response	
Field Name	Hex
Slave Address (Device ID)	01h
Function	10h
Starting Address High	00h
Starting Address Low	3Ch
Number of Register High	00h
Number of Register Low	04h
CRC Code High	XX
CRC Code Low	XX

① Read (Read Holding Registers)

Request
Field Name
Slave Address (Device ID)
Function
Starting Address High
Starting Address Low
Number of Register High
Number of Register Low
CRC Code High
CRC Code Low

Response	
Field Name	Hex
Slave Address (Device ID)	01h
Function	03h
Byte Count	08h
Date High	00h
Date High	03h
Date Low	38h
Date Low	45h
Time High	00h
Time High	02h
Time Low	2Eh
Time Low	A7h
CRC Code High	XX
CRC Code Low	XX

9. ModBus-TCP

ModBus-TCP is a ModBus protocol that operates over TCP/IP networks, enabling communication on Ethernet-based systems.

i Only one socket is supported.

9.1 ModBus-TCP frame structure

MBAP Header				Function code	Data
Transaction ID	Protocol ID	Length	Unit ID	Function code	Data

ModBus-TCP consists of MBAP, followed by Function code and Data. MBAP has a total of 7 bytes and represents the byte value as follows.

Transaction ID [2Bytes]	The client increases the value by 1 starting from 0x0000. Server copies and uses this value as is.
Protocol ID [2Bytes]	Use a fixed value of 0x0000.
Length [2Bytes]	Indicates the number of bytes from Unit ID to the end of data.
Unit ID [1Bytes]	Use a fixed value of 0x01.

Function code and data are the same as ModBus_RTU.

Please refer to Chapter 10 ModBus-RTU (excluding CRC).

9.2 Command Reception Mode

Command reception mode is a serial communication mode used for operating as a secondary display. It functions separately from comparator mode, which operates independently.

1) Hardware Connection

Connect the RS-232 ports of the AN310 (main unit) and AN310 (secondary display) in a 1-to-1 configuration as shown below:

Master (Main Unit)	Client (Secondary Display)
TXD	RXD
RXD	TXD
GND	GND

2) Communication Settings

RS232 Setting Data	Master	Client
Communication Mode	Command	Command Reception

Ensure that the communication settings (baud rate, data bits, stop bits, parity) on both devices are identical.

3) Client Command Operations

The client's commands for zero, tare, gross, and net , G/N are executed by the master. Other commands (e.g., hold, reset) are performed directly by the client.

10. Error Messages

CH 01	The measured value exceeded the maximum capacity.
CH 02	Check the connection status of the measurement sensor.
CH 03	Check the comparator mode setting value.

Please **Contact Our Authorized Dealer** for Technical Assistance:

Empty rectangular box for notes or technical assistance details.

Notes:



9001:2015



14001:2015



45001:2018