

OCSG Series



FEATURES

- Fast resolution switching
- 30mm 5 digits LED display
- Fixed hook
- Idle mode to maximize the battery life
- HOLD function
- Tare In / Tare Out
- Unit switch: kg / lb
- Auto overload alarm at 100%F.S. +9e
- Auto power-off function

CRANESCALE

Model	OCSG1
Type	Heat Resistant
Accuracy Class	OIML III
Enclosure	Die-casting Aluminum
Display	30mm LED
Capacity Available	6 / 10 / 20 / 30Klb
Battery Life	100Hours
High Quality Load Receptor	Alloy Steel
Shackle	H.D. Bow
Hook	H.D. Eye
High Capacity Rechargeable	Yes
Battery	6V/10Ah
Infrared Remote Control	Yes

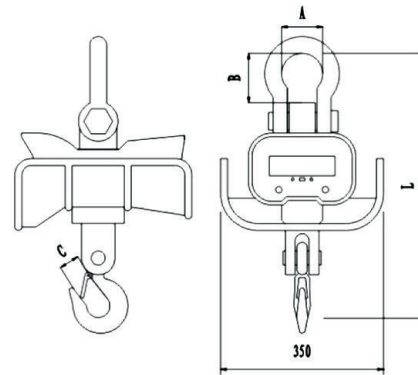

Rated Capacity	Division	A	B	C	L	N.W.	G.W.
6Klb	1kg / 2lb	92mm/3.62"	100mm/3.94"	55mm/2.17"	730mm/28.74"	33kg/72.8lb	36kg/79.4lb
10Klb	2kg / 5lb	98mm/3.86"	125mm/4.92"	70mm/2.76"	850mm/33.46"	46kg/101.4lb	59kg/130.1lb
20Klb	5kg / 10lb	130mm/5.12"	140mm/5.51"	70mm/2.76"	900mm/35.43"	64kg/141.1lb	69kg/152.1lb
30Klb	5kg / 10lb	130mm/5.12"	160mm/6.30"	75mm/2.95"	950mm/37.40"	70kg/154.3lb	85kg/187.4lb

*Dimensions and specifications are subject to change without notice.