

1. Special Features

- Can be connected with 8 single cells
- Each connection has independent adjustable resistance, signal trim, section trim
- Stainless steel SS304
- Unique patented design, easy for installation, never-lose bolts

2. Dimensions (in mm; 1mm=0.03937 inches)

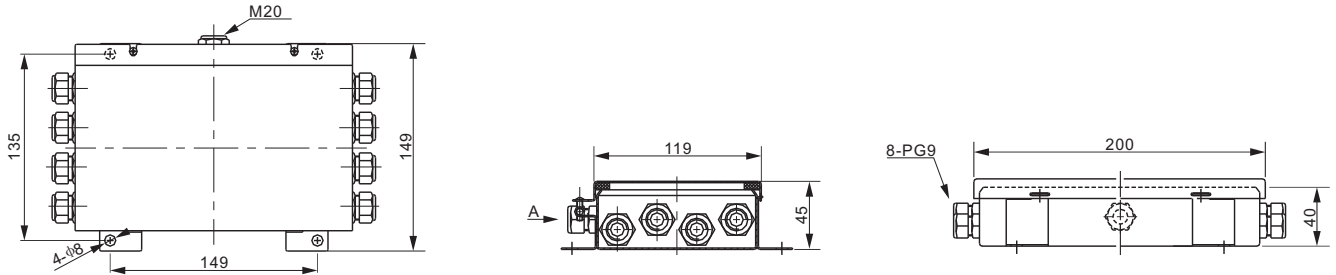

3. Connection Diagram

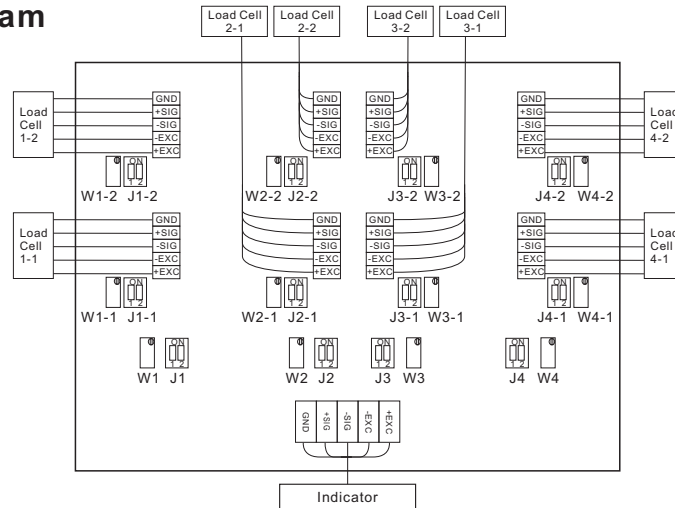

4. Technical Data

Type	J08SS	
Trimming	Signal trim, section trim	
Weight, approx	kg	0.9
Max. Permissible Voltage	V	18
Materials	Stainless steel SS304	
Outline (L*W*H)	mm	200*149*45
Nominal Temperature Range	°C [°F]	-10...+50 [14...122]
Storage Temperature Range		-20...+60 [-4...140]
Cable Connection for Cable Diameter		Input: PG9: 4-8mm, Output: M20: 6-12mm
Protection Class According to IEC529		IP65

5. Application

8 channel signals generated from the load cells which distributed at the corners of the weighing platform, synthesize into one channel signal and send to the weighing indicator after balance adjustment.

6. Trimming Procedure

Trimming is a process of equalizing the output from multiple individual load cells by adjusting each matched potentiometer.

Tools needed: a) A flat head screwdriver which is good for potentiometer adjustment and a Phillips screwdriver which is good for fasten bolts;

b) A 4.5 digits(at least) multi-meter.



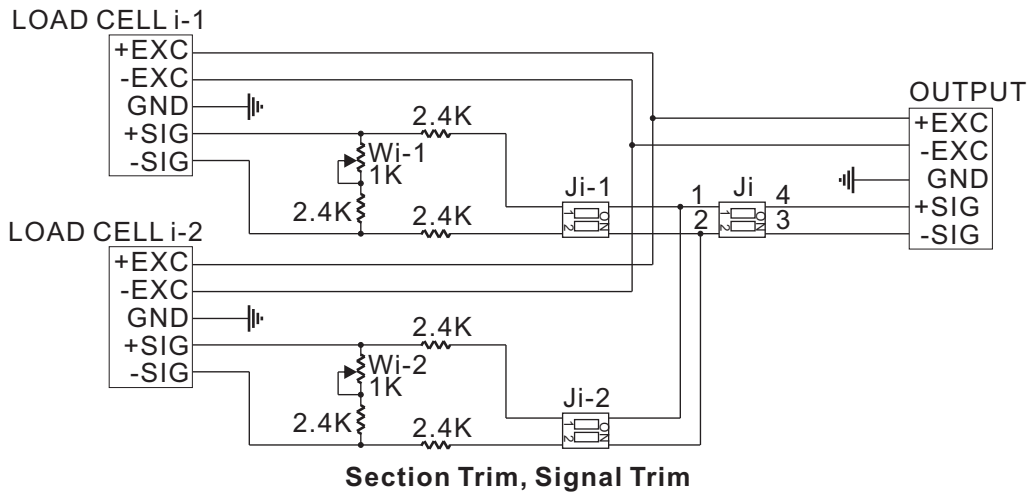

6.1 Trimming individual Load Cell

- 1) Connect each load cell cable to the matched terminal of J08SS through PG9 as “Connection Diagram” shown above, connect indicator with a cable through M20 connector with J08SS properly as well. Set dip switches all in the ON position. Set the indicator to Zero, then place test weights over each load cell (each corner) and on the center point in turn. For an eight load cells scale, it is recommended using a weight of 25% of full scale capacity.
- 2) Record the value displayed on the indicator after test weight is placed in turn on each corner and center. Select the lower corner value comparing with center value, adjust the potentiometer of the corner by clockwise turn to increase the value of this corner, or select the greater value comparing with center value, then trim the potentiometer of the corner by counterclockwise turn to decrease the value of this corner.
- 3) Replace the same test weight over each cell and center in turn. Adjust the potentiometers to trim each load cell up or down to equal the value of each corner to the center. Check all cells again for repeatability, repeat steps 1 and 2 if necessary until all the value is within the required range.
- 4) Place the box cover on and tighten the cover screws, make sure the gasket is compressed equally in all locations.

6.2 Trimming load cells in sections

Trimming load cells in sections assumes there are an even number of load cells to be trimmed in pair. With J08SS, you can trim at most 8 load cells in 4 sections. Dip switches Ji-1, Ji-2 (i=1,2...4) are used for enabling or disabling each load cell connected to the junction box. Set the dip switches in the ON position to enable the load cell, set the dip switches in the OFF position to disable the load cell. Dip switches Ji (i=1,2,...4) are used for enabling or disabling each section.

Follow the procedures below to trim load cells in sections:

- 1) Follow the procedures in Trimming individual Load Cells steps 1 for cable connection.
- 2) Enable section1, enable load cell1-1, disable other load cells. Set the indicator zero, then place test weights over the load cell1-1 and on the center point. Enable load cell1-2, disable other load cells, place test weights over the load cell connected to the terminal1-2. For an eight load cells scale, it is recommended using a weight of 25% of full scale capacity.
- 3) Record the value displayed on the indicator after test weight is placed over the load cell1-1 and 1-2. Select the lower value comparing with center value, adjust the potentiometer W1-1 and W1-2 by clockwise turn to increase the value of this corner, or select the greater value comparing with center value, then trim the potentiometer of the corner by counterclockwise turn to decrease the value of this corner.
- 4) Adjust the potentiometers W1-1 and W1-2 to trim each load cell up or down to equal the value of each corner to the center. Check all cells again for repeatability, repeat steps 2 and 3 if necessary until all the value is within the required range. Complete the trimming of other sections with the similar method.
- 5) Enable each section, and disable the others. Set the indicator zero, then place test weights over the load cells of each section and on the center point. Record the value displayed on the indicator. Select the lowest value comparing with center value, adjust the potentiometer in each section by clockwise turn to increase the value of this section, or select the greatest value comparing with center value, then trim the potentiometer of the section by counterclockwise turn to decrease the value of this section.
- 6) Check all cells again for repeatability, repeat steps 5 if necessary until all the value is within the required range. Place the box cover on and tighten the cover screws, make sure the gasket is compressed equally in all locations.